

Thank You

We appreciate your purchase of the PianoDisc system. PianoDisc elegantly integrates advanced player piano technology and modern music production capabilities, and will provide you with many years of enjoyment. In order to utilize the system to its fullest extent, please read and understand all the information contained in this user's guide.

For your future reference, please copy the serial number of your PDS-228CFX below, and fill in the purchase date and the name and telephone number of your PianoDisc dealer.

SERIAL NUMBER: _____

PURCHASE DATE: _____

DEALER NAME: _____

DEALER PHONE NUMBER: _____

PianoDisc® PDS-228CFX
User's Guide (April 2004)
Distributed with PDS-228CFX, featuring OS Version 4.2
© Copyright 2000 Burgett, Inc. All rights reserved.

PianoDisc
4111 North Freeway Boulevard
Sacramento, CA 95834
(916) 567-9999
(916) 567-1941 Fax

The PianoDisc System is covered under the following U.S. Patents:
5,083,491; 5,237,125; 5,251,529; 5,521,795; 5,524,521; 5,542,328; 5,546,842; 5,756,910; 5,834,669; 5,841,050.
Other patents pending.

PianoDisc and QuietTime are registered trademarks of Burgett, Inc.
PianoCD is a trademark of Burgett, Inc.
Yamaha, PianoSoft, PianoSoft Plus, and Disklavier are registered trademarks of Yamaha Corporation.
Roland is a registered trademark of Roland Corporation.

At the time of printing, all information contained in this manual was deemed to be completely accurate.
PianoDisc reserves the right to change specifications or design at any time without prior notice.

IMPORTANT: READ THIS FIRST!

Safety Instructions

SPECIAL MARKINGS

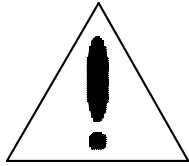

This symbol is intended to alert the user to the presence of important operating and maintenance (servicing) instructions in the literature accompanying the product.

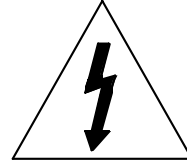

This symbol is intended to alert the user to the presence of uninsulated dangerous voltage within the product's enclosure that may be of sufficient magnitude to constitute a risk of electric shock to persons.

	CAUTION RISK OF ELECTRIC SHOCK DO NOT OPEN	
CAUTION: TO REDUCE THE RISK OF ELECTRICAL SHOCK, DO NOT REMOVE COVER OR BACK. NO USER-SERVICEABLE PARTS INSIDE. REFER SERVICING TO QUALIFIED SERVICE PERSONNEL.		

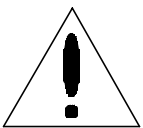

IMPORTANT NOTICE: Complete Safety of operation is assured by PianoDisc when system is properly installed and operated in its normal fashion. Do not attempt, or commission others, to modify any portion of the PianoDisc system unless specifically authorized by PianoDisc.

IMPORTANT SAFETY AND INSTALLATION INSTRUCTIONS

INFORMATION RELATING TO POSSIBLE PERSONAL INJURY, ELECTRIC SHOCK AND FIRE HAZARD POSSIBILITIES HAS BEEN INCLUDED IN THIS LIST.

WARNING - When using electrical products, basic precautions should always be followed, including the following:

1. Read all instructions before using the product.
2. The product should be connected to a power supply only of the type described in the operating instructions or as marked on the product.
3. Do not open the cover under any circumstances.
4. Power is supplied through a polarized line plug (one way blade). Connect only to an outlet designed for a polarized plug.
5. Keep the power cord away from other objects. Make sure that the cord is not twisted, placed in any lane of traffic, or trapped under the piano.
6. Locate your PianoDisc unit away from direct sunlight, water or moisture, or hot or cold air currents.
7. If the PianoDisc unit is to remain unused for an extended period of time, its power supply should be disconnected.
8. If repair is necessary, refer only to authorized service personnel.
9. This product, either alone or in combination with an amplifier and headphones or speakers, may be capable of producing sound levels that could cause permanent hearing loss. Do not operate for a long period of time at a high volume level or at a level that is uncomfortable. If you experience any hearing loss or ringing in the ears, you should consult an audiologist.
10. The product should be located so that its location or position does not interfere with its proper ventilation.
11. Care should be taken so that objects do not fall and liquids are not spilled into the enclosure through openings.
12. The product should be serviced by qualified service personnel when:
 - a) The power supply cord or the plug has been damaged; or
 - b) Objects have fallen, or liquid has been spilled onto the product; or
 - c) The product has been exposed to rain; or
 - d) The product does not appear to operate normally or exhibits a marked change in performance; or
 - e) The product has been dropped, or enclosure damaged.

SAVE THESE INSTRUCTIONS

FCC Information

NOTE: This equipment has been tested and found to comply with the limits for a Class B digital device, pursuant to Part 15 of the FCC Rules. These limits are designed to provide reasonable protection against harmful interference in a residential installation. This equipment generates, uses, and can radiate radio frequency energy. If it is not installed and used in accordance with the instructions, it may cause harmful interference to radio communications. However, there is no guarantee that interference will not occur in a particular installation. If this equipment does cause harmful interference to radio or television reception, which can be determined by turning the equipment off and on, the user is encouraged to try to correct the interference by one or more of the following measures:

- Reorient or relocate the receiving antenna.
- Increase the separation between the equipment and receiver.
- Connect the equipment into an outlet on a circuit different from that to which the receiver is connected.
- Consult the dealer or an experienced radio/TV technician for help.

CAUTION: CHANGES OR MODIFICATIONS NOT EXPRESSLY APPROVED BY THE PARTY RESPONSIBLE FOR COMPLIANCE COULD VOID THE USER'S AUTHORITY TO OPERATE THE EQUIPMENT.

Caring For Your PianoDisc Music Library Diskettes

By following these simple guidelines, your collection of PianoDisc Music Library diskettes should provide a lifetime of musical enjoyment:

- Do not eject the diskette when the disk drive light is on or during playback. (The disk drive light is the green or amber light directly below the disk drive opening.)
- Avoid turning the main power on and off while playing a diskette. First stop playback, then turn off the power.
- Store your diskettes in a cool, dry place, away from direct sunlight, heat, cold, or any moisture.
- Keep diskettes in their protective cases when not in use to protect them from dust and mishandling.
- Do not subject your diskettes to violent vibrations or shocks; do not try to take them apart or tamper with the casings.
- Keep your diskettes away from electrical appliances, magnets, or anything else capable of producing a magnetic field.
- Insert your diskettes into the PDS-228CFX as shown below, with the label side up.

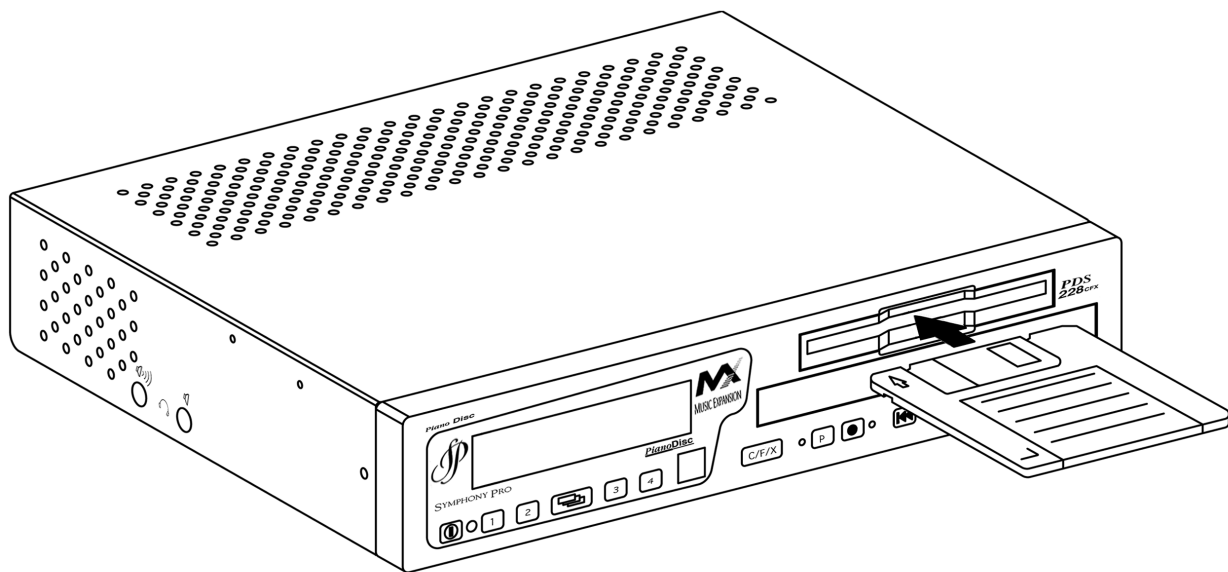

Caring For Your PianoDisc Compact Discs (CDs)

By following these simple guidelines, your collection of PianoDisc Compact Discs (CDs) should provide a lifetime of musical enjoyment:

- Keep your compact discs in their protective case when not in use to protect them from dust and mishandling.
- Store your compact discs in a cool, dry place, away from direct sunlight, heat, cold, or any moisture.
- If using an external CD player, review care and handling instructions in your compact disc player user's manual.
- Place the compact disc in the tray with the label facing up as shown below.

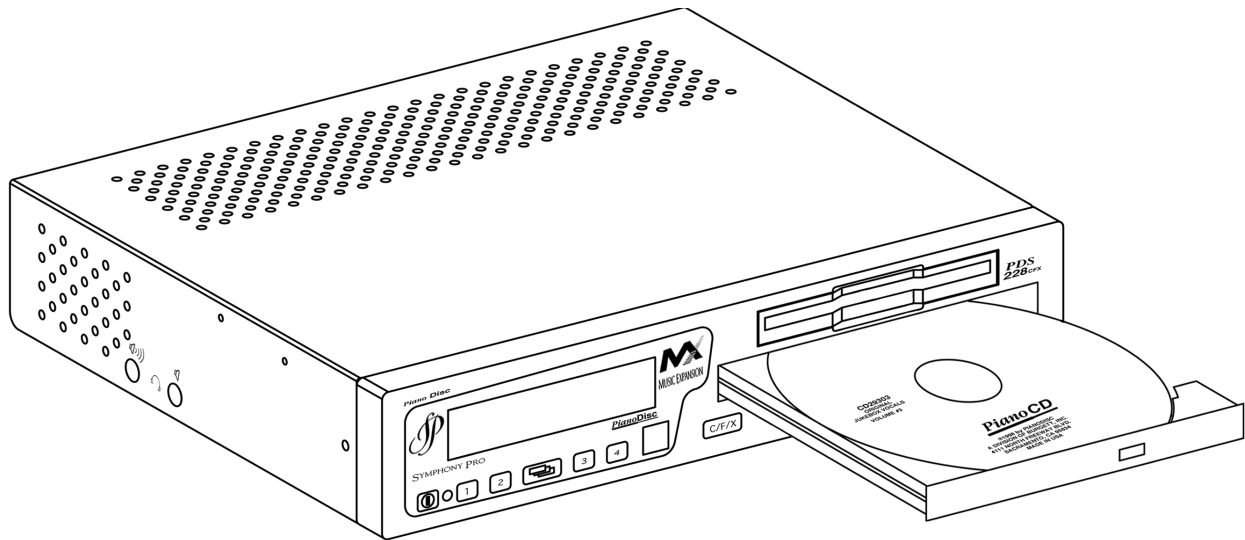

NOTE:

Both portable and full size CD players can be used with the PDS-228CFX System along with its own internal CD player. Because the quality of the CD player will affect the performance of the player system, make every effort to ensure fresh batteries are in the portable CD player. It is highly recommended that an AC adapter be used.

Full size CD players include advanced features like digital filtering or special DSP effects. Disable these features or similar ones when playing PianoDisc PianoCDs.

For best results, use an internal or external *PianoCD* unit, which has an integrated CD player.

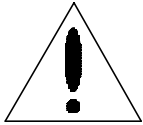

General Operating Notes

- When the control unit is turned off from the front panel, the unit will continue to consume power (approximately 1.5 W) and generate a minimal amount of heat. Unplugging the piano from the power source will completely shut down the unit unless the control unit is being powered by its own power supply.
- Make sure the control unit has adequate ventilation underneath, behind, and on top. Do not place the PDS-228CFX on a cushioned surface such as a pillow or towel.
- The PianoDisc PDS-228CFX is used with an acoustic piano and a mechanical drive system—it cannot be manipulated like a home stereo. Changes in volume and tempo may alter the playback in ways you may not have anticipated.
- The PDS-228CFX can be purchased with, or upgraded to, an internal symphony module that provides additional sounds and instruments that can play along with your piano.
- The features and operations of the PDS-228CFX, with the internal module, are identical to the PDS-228CFX without the internal module, except for a few functions. Users of the PDS-228CFX without the module should ignore any information in this guide regarding the internal symphony module.
- The PDS-228CFX can be purchased with, or upgraded to, the Music eXpansion option, offering many hours of uninterrupted, user-customizable playback.
- Users of the PDS-228CFX without *MX* should ignore any information* in this guide pertaining to its unique capacity (focused in the “*MX* (Music eXpansion Option” Section).
- Refer to the “*MX* Mode “ section to consider compelling reasons to upgrade to *MX*.
- The PDS-228CFX can be purchased with—or upgraded to include—a CD ROM Drive. The internal CD ROM Drive is a Class 1 Laser Product.

*For instance, some references to the SOURCE options throughout this User Guide will mention *MX*. If this option is available to you, it will display on-screen. If not, it is hidden from view to keep menu navigation clear.

Table of Contents

Section I Description of PianoDisc Equipment	1
PDS-228CFX Front Panel	2
PDS-228CFX Rear Panel	5
PDS-228CFX Side Panel	7
Description of Features and Controls	8
 Section II <i>Quick-Start</i> Guide to Playing Music (from Diskette, CD, or MX)	9
 Section III Floppy Disk Mode	13
Floppy Disk Mode Information	14
The Mode Pages	15
Tour of the Menus	16
TEMPO	16
TRANSPOSE	16
BALANCE	17
AUTO	17
PIANO MUTE	18
SPLIT	18
ACCOMPANIMENT	20
EDUCATION	22
DISK REPEAT	23
SONG REPEAT	23
SHUFFLE	24
GLOBAL REPEAT	24
SCOPE	25
SYNC	25
MIDI IN	26
MIDI OUT	26
REDIRECT	27
PASSTHROUGH	28
SOURCE	28
DEFAULT	28
ERASE	29
NAME	30
FREE	31
FORMAT	31
 Front Panel Functions	32
PRODUCER	32
RECORD	33

Section IV CD Mode	37
CD Mode Information	38
The Mode Pages	39
SYNC	40
BALANCE	40
SHUFFLE	41
GLOBAL REPEAT	41
TRANSPOSE	42
MUTE	43
PIANO MUTE	43
SOURCE	43
DEFAULT	44
TREBLE	44
BASS	44
BYPASS	45
DEFEAT	45
Section V MX Mode	47
MX Mode Information	48
The Mode Pages	49
Enhancements to Mode Page 1	50
SCOPE	50
DISK REPEAT	50
SHUFFLE	51
GLOBAL REPEAT	51
LIBRARY	52
NAME	52
COPY	53
ERASE	53
MASK	54
PRODUCER	55
Section VI Remote Control	57
Remote Control Description	58
Direct Song Access	61
Remote Control Type	61

Section VII Appendices63
A. Accompaniment Mode Instrument List64
B. System Exclusive Messages (SYSEX)	65
C. Music Software Formats	68
D. Using Educational Software69
E. CPU Interface71
F. Connecting the PDS-228CFX to a Stereo or Home Entertainment System72
G. Connecting the PDS-228CFX to a Computer73
H. Software Upgrade Information74
I. Troubleshooting75
J. MIDI Implementation Chart77
K. MX Song List (Alphabetical within Library)78
L. Specifications for PDS-228CFX Units89
M. Quiet Time/Silent Function90
N. Index91



Section I

Description of PianoDisc Equipment

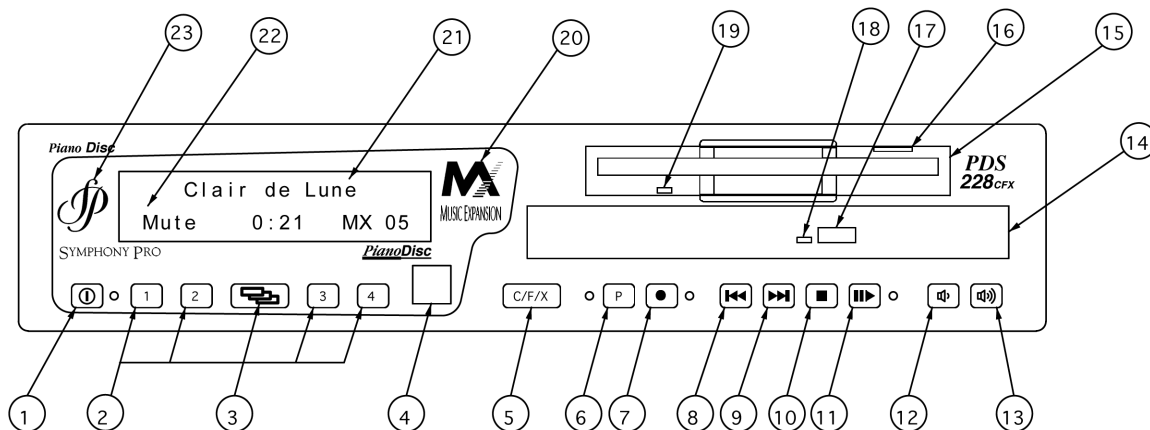
PDS-228CFX Front Panel



1. **POWER:** Turn power on, off.
2. **FUNCTION BUTTONS:** Used to select modes, and to make changes or choose options during MODE operations. Buttons [1] and [4] are typically used to decrease and increase settings, while buttons [2] and [3] normally return settings to default values.
3. **MODE:** Push and release to display menus; select options by using function buttons. Hold to view media type or—with *MX* option—current library.
4. **I.R. SENSOR:** Receives the commands from the remote control.
5. **SOURCE:** Press to choose source of music: CD, FLOPPY DISK or MX.
6. **PRODUCER:** Used for advanced playback customization.*
7. **RECORD:** If piano is equipped with a *Record Option*, records performance onto a diskette or into an *MX* library (where *MX* option is installed).*
8. **SCAN BACKWARD:** When playback is stopped, pressing [SCAN<<] steps through song selections in reverse order. When playback is engaged, pressing [SCAN<<] returns playback to the beginning of the song being played.
9. **SCAN FORWARD:** When playback is stopped, pressing [SCAN>>] steps forward through song selections. When playback is engaged, press and release [SCAN>>] to advance to next song. To “fast-forward” during playback, hold down the [SCAN>>] button.

10. **STOP:** Stops playback or exits the current mode. Also ejects the CD in CD mode.
11. **PLAY/PAUSE:** Press to play; press again to pause. During playback, the green light next to the PLAY/PAUSE button will be illuminated. When playback is paused, the green light (LED) will flash.
12. **DECREASE VOLUME:** Press  to decrease volume.
13. **INCREASE VOLUME:** Press  to increase volume.
14. **CD DRIVE:** Used for reading a PianoDisc CD (or a standard audio CD).
15. **DISK DRIVE:** Used for reading and writing data onto a 3.5 inch disk.
16. **DISK EJECT:** Press to eject disk from disk drive.
17. **CD EJECT:** Press to open the CD tray.
18. **CD ACTIVITY LIGHT:** Illuminated when the drive is active.
19. **DISK DRIVE ACTIVITY LIGHT:** Illuminated when the disk drive is active.
20. **MX LOGO:** Indicates whether this PDS-228CFX is equipped with the *MX* option.
21. **LCD DISPLAY:** 20 character, 2 line display shows current system status and dynamic button choices.
22. **PLAYBACK STATUS:** The display indicates which function is active: mute, piano mute, song repeat, disk repeat, global repeat, shuffle, etc.

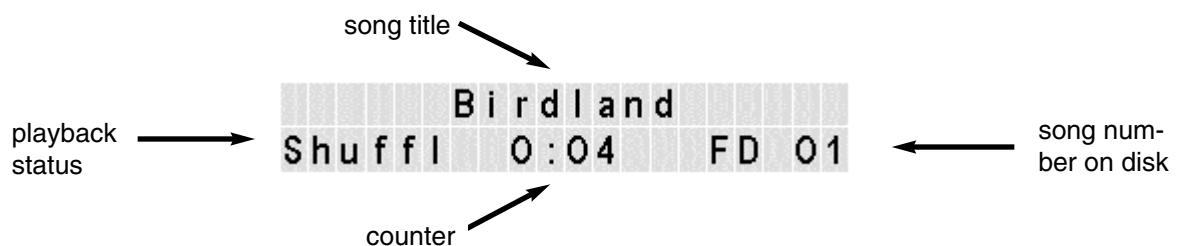

23. SYMPHONY LOGO: Indicates whether this PDS-228CFX is equipped with the SymphonyPro option.

* The PianoDisc PDS-228CFX has many more capabilities that are not immediately apparent from the front panel. For a general introduction to these advanced functions, refer to “Descriptions of Features and Controls”, page 8, and PRODUCER, RECORD sections, pages 32-35.

PDS-228CFX Rear Panel

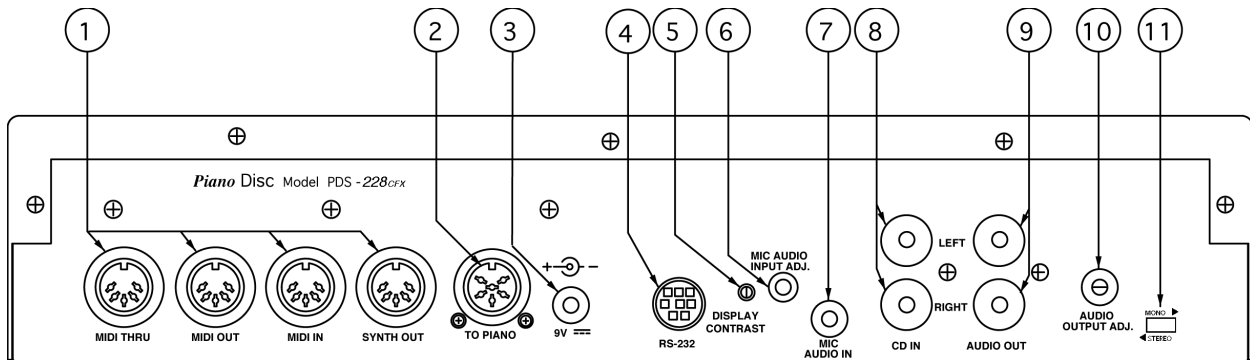

- 1. MIDI PORTS:** Used to connect the PianoDisc PDS-228CFX control box to an external MIDI device via MIDI cables. MIDI cables are 5-pin connectors available in various lengths. Care should be taken to avoid damaging the pins when inserting them into the MIDI ports.

MIDI THRU: Echoes, or duplicates MIDI data received from MIDI IN.

MIDI OUT: Transmits MIDI data unaffected by most front panel controls. MIDI OUT also has several alternative functions, such as to provide the pathway for “link mode” with the PianoCD.

MIDI IN: Receives MIDI data from an external MIDI device, such as a keyboard, sequencer, or computer.

SYNTH OUT: Sends MIDI data for an external synthesizer. It is not necessary to use SYNTH OUT if the PDS-228CFX is equipped with the symphony option.

- 2. TO PIANO:** This special 6-pin DIN port is used to connect the PDS-228CFX to a piano fitted with the PianoDisc system, allowing information to and from the piano to be transmitted over one cable. Power to the PDS-228CFX unit is supplied with this same cable.

- 3. DC POWER CONNECTOR:** This connector is for connecting the PDS-228CFX to a stand-alone 9 volt transformer, (ordinarily the PDS-228CFX is powered through the “To Piano” port by means of a special 6-pin DIN cable). If a DC power supply

is necessary, it must be purchased from PianoDisc. DO NOT attempt to use an off-the-shelf power supply to power the PDS-228CFX control unit.

4. **RS-232 PORT:** This port is for high speed data transfer with a computer or an external expansion option.
5. **DISPLAY CONTRAST:** This small control may be used to adjust the display so it can be seen at the desired viewing angle.
6. **AUDIO INPUT CONTROL:** This adjusts the volume of the AUDIO INPUT signal.
7. **AUDIO IN:** 1/8" mono jack for microphone or other audio input signal which will be heard through AUDIO OUT.
8. **CD IN CONNECTORS:** These are to be used for the CD mode. Connect the AUDIO OUTs of a CD player to these ports.*
9. **AUDIO OUT CONNECTORS**:** These are used to connect a PDS-228CFX to a listening device, such as a pair of amplified speakers. If only one amplified speaker is to be connected to the PDS-228CFX, slide the mono/stereo switch to mono.
10. **AUDIO OUTPUT CONTROL:** Controls the master volume.
11. **MONO/STEREO SELECTOR SWITCH:** This switch should be set to STEREO to take advantage of both left and right audio output channels (both speakers). If your setup uses only one channel of audio output, e.g., if playback is to be heard from only one speaker, set this switch to MONO.

* These inputs are designed to accept a line level signal up to 1 volt RMS each. Because the inputs are designed to work with consumer-grade CD players at *line level*, **avoid** connecting amplified signals to these inputs.

The audio output of the PDS-228CFX **IS NOT a speaker output. This system must be connected to an amplified device, such as the aux. input of a stereo system or the line level input of a musical instrument or PA system. The audio output of the PDS-228CFX sums (mixes) the output of the internal symphony option and the audio input jacks. The output level is attenuated (turned down) by the AUDIO LEVEL ADJUST OUTPUT control located on the rear panel of the PDS-228CFX.

PDS-228CFX Side Panel

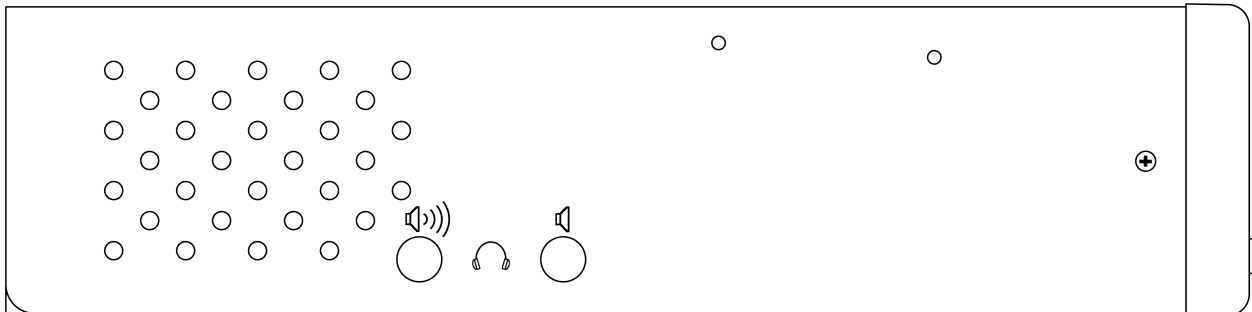

STEREO HEADPHONES

There are two stereo headphone jacks on the side of the PDS-228CFX Control Box. The left jack duplicates the *Audio OUT** signal to the speakers (*i.e.*, both speakers and headphones will receive audio output signal, meaning that you will hear sound from both simultaneously). Plugging headphones into the right jack will disable output to the speakers (leaving only the sound coming from the headphones). (See diagram above.)

Before playing any music (especially through headphones!), lower the audio level to a **low setting** from the front panel. Then, for best playback results, set the audio out adjustment on the rear panel to 1/8 turn from maximum. Start your music playback. (Details on following pages.) Finally, return to the front panel to raise volume to a suitable level.

**Audio OUT* is the mix of *Audio IN* and accompanying sounds from the sound module (Symphony Option) and CD.

Description of Features and Controls

The PDS-228CFX front panel was designed to offer easy and convenient access to the most important controls.

Buttons on the front panel, such as PLAY, RECORD and VOLUME, are readily apparent. The advanced functions are accessed by pressing the MODE button. A new screen is displayed for each function. To select one of the options displayed on the mode pages, or to make a change, simply press the numbered button directly below the desired choice. To help you, next to each function listed is a small “menu-flow” diagram that shows the necessary steps to access that function. For example, see the following diagram:

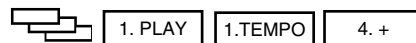

To increase the tempo in floppy disk mode, first press the MODE button once, then [1] (PLAY), [1] (TEMPO) and [4] and hold to increase the tempo.

A Note About Pressing Buttons

The buttons on the PDS-228CFX are very responsive to touch, and should not be pressed with excessive force. To save time, (*e.g.*, while changing tempo or transposing a song) the button may be held down to induce a continuous change. All changes are reflected in the display. If no change occurs, release the button and try again.

Section II

Quick-Start Guide

QUICK-START

This section shows you how to get “up and running” with your PianoDisc system in a matter of minutes.

Have a PianoDisc diskette or CD ready (for playback from PianoCD or an external audio CD player).

Step 1: Press the Power Button

Find the POWER button on the front face of the PDS-228CFX. When you press it, your player system will turn on. The LED indicator (green light) beside the POWER button will glow, to confirm that the power is “On.”

Reviewing System Info

When the screen shown below appears, press [1] and hold to view the options installed with your system. Then press [4] to page through the info screens and to EXIT. Your PDS-228CFX will finish booting.

If no keys are pressed, your PDS-228CFX will boot automatically.

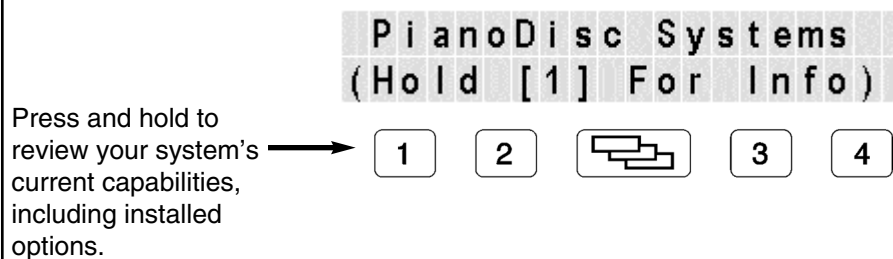

Step 2: Set a Safe Volume Level

Warning! Press VOLUME  and set at a low setting before you press PLAY.

After you have begun playback, then raise the volume to suit your ears and environment.

Step 3: Choose your Music Source

C/F/X

Press the SOURCE button to toggle through your choices: FD, CD or MX.*
Then press OK [4] to confirm your selection.

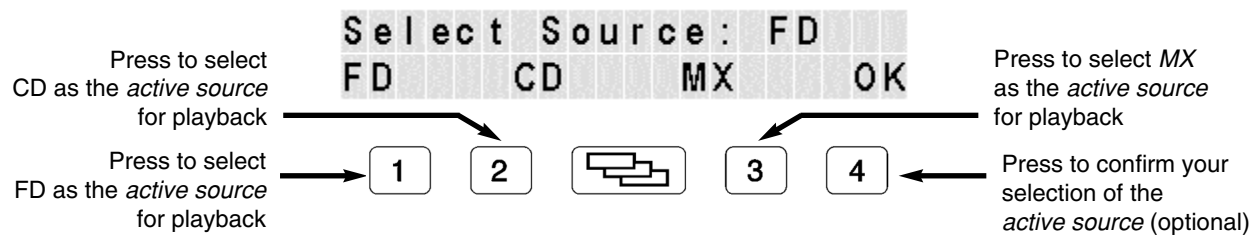

Step 4: Play

Press [PLAY] on the front panel to begin playback of your favorite music.

* Some users will not see this option displayed because they have not purchased the MX (Music eXpansion) card. Contact your dealer or PianoDisc for an upgrade to your existing system.

Section III

Floppy Disk Mode

PDS-228CFX “Floppy Disk Mode”

All PDS-228CFX units are equipped with an internal floppy drive. The PDS-228CFX is able to read many music formats, including PianoDisc’s extensive music library. If you have a computer, you can even create your own music disks and play them in your PianoDisc system. In Floppy Disk Mode, you can also record music from your piano (requires a Record Option), as well as customize disks. The following is a summary of the PDS-228CFX’s floppy disk capabilities:

- Plays the piano and the SymphonyPro (or external sound module).
- Reads PianoDisc Double Sided Double Density (DSDD) and Double Sided High Density (DSHD) floppy disks.
- Reads PianoSoft™ DSDD floppy disks.
- Reads PC-formatted DSDD and DSHD disks containing Standard MIDI Type 0 files.
- Reads educational Standard MIDI Type 0 disks and allows the left hand, right hand, or both to be toggled.
- Records to PianoDisc floppy disks.
- Formats PianoDisc floppy disks.
- Allows individual songs to be renamed or erased from PianoDisc floppy disks.
- Allows a customized playback order (via Producer Mode) on PianoDisc disks.
- Stores up to 70 songs on PianoDisc disks.
- Stores up to 70 songs on PianoSoft disks.
- Stores up to 99 songs on PC-formatted disks.

Selecting FLOPPY DISK MODE

C/F/X

1.FD

To play back from (or record onto) a floppy diskette, press the Source button and select FD. After a slight delay, the letters **FD** will be displayed in the lower right hand corner with the current song number.

The Mode Pages

Push the MODE button to display even more functions. There are three pages. The first (press MODE once) contains PLAY, KEYBOARD, REPEAT, and SCOPE. The second page (press MODE again) contains SYNC, MIDI, SOURCE and DEFAULT. The third page* contains the *Disk Options*: ERASE, NAME, FREE, and FORMAT.

The following diagrams show the three mode pages available in FLOPPY DISK MODE. To select a function, simply press the numbered button directly below the desired function. A new screen will be displayed for each function.

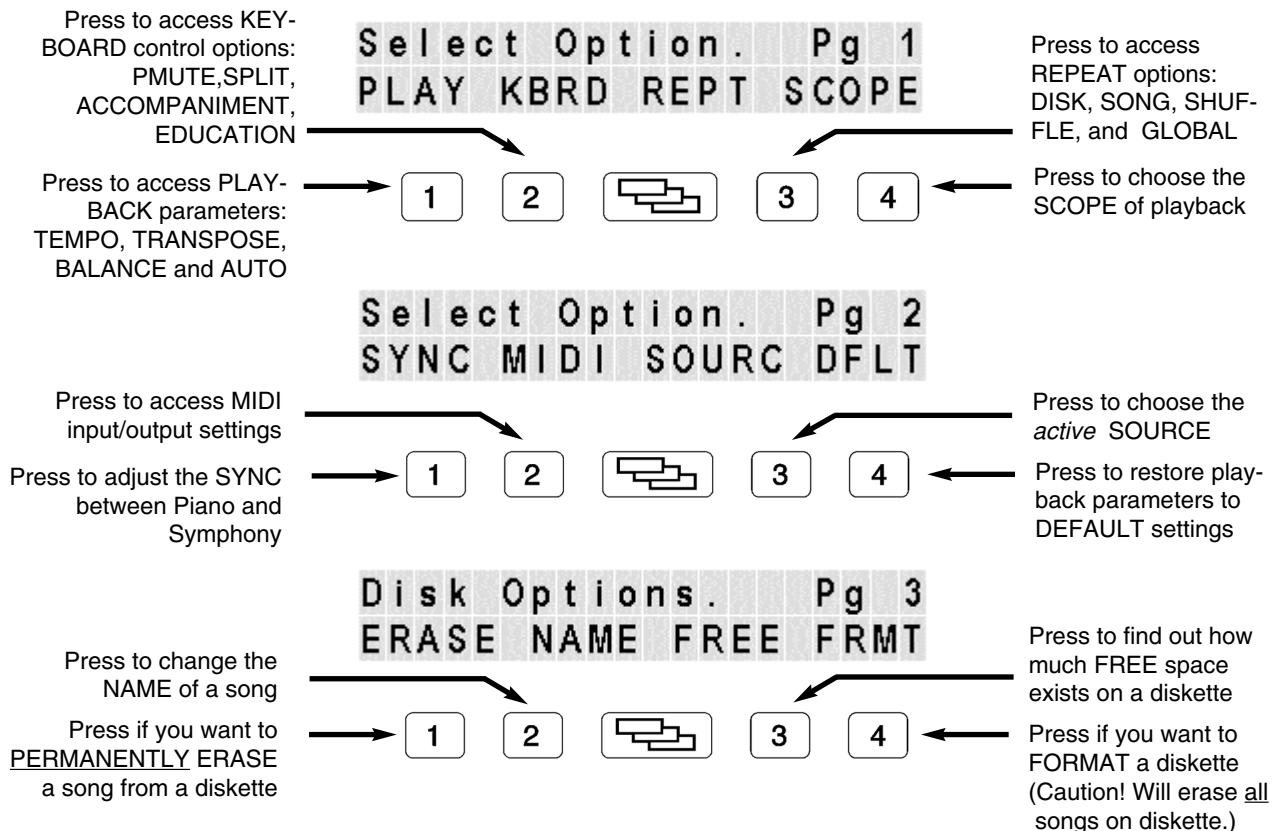

*The third mode page (shown immediately above) is available only when a PianoDisc floppy disk is in the drive. It is not available during playback or when a *non*-PianoDisc floppy disk is installed.

Tour of the Menus

Mode Page #1

TEMPO

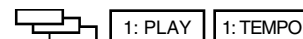

The TEMPO function may be used to adjust the playback speed of a song. The bar display indicates the relative tempo of the song, with the middle position being the original tempo of the song. Pressing “+” (the [4] button) will increase the tempo, while pressing “-” (the [1] button) will decrease the tempo. Pressing the [2] or the [3] button will return the song to its original tempo.

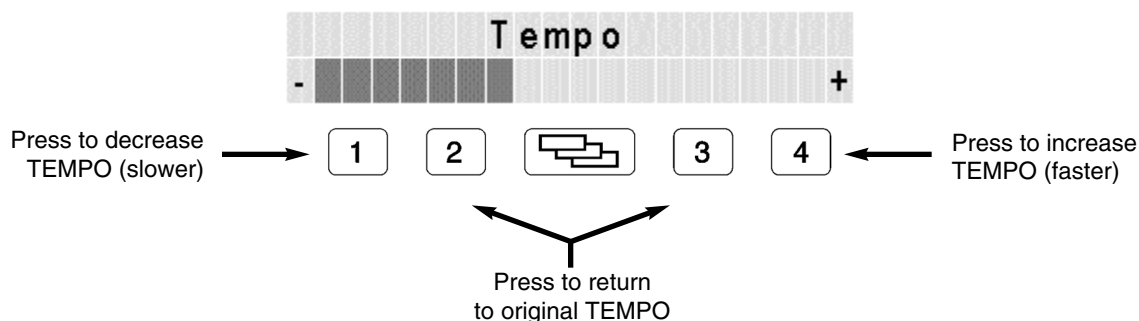

Note: The tempo display for Yamaha and SMF disks is slightly different.

TRANSCOPE



The TRANSCOPE function changes the pitch of the song in half-step increments. (A half-step is the interval between any two adjacent notes on the piano, e.g. C and C-sharp; one octave is equal to 12 half-steps.) This function is useful when a vocalist is singing with the piano and would prefer to sing in a different key. Transposing down moves the song toward the bass end of the piano, while transposing up has the opposite effect. This function is effective up to two full octaves (24 keys) in either direction.

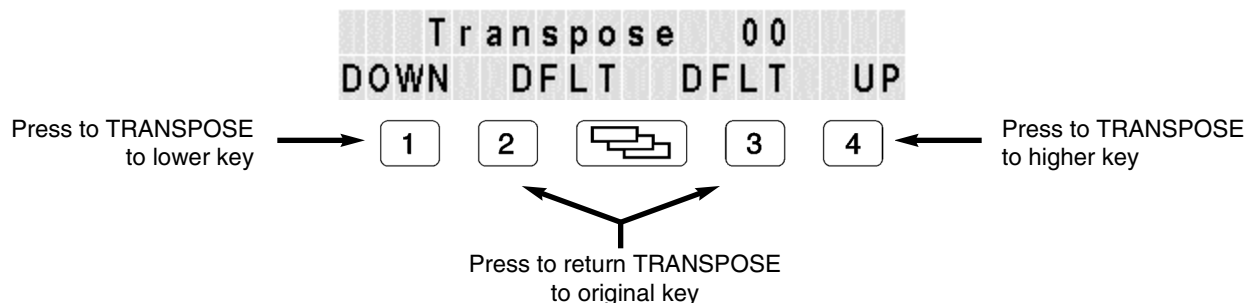

BALANCE



The BALANCE function controls the mix, or relative volumes, between the symphony and piano outputs of the PianoDisc system. Moving the bar display toward the “S” (by pressing the [1] button) raises the volume of the symphony portion of the music relative to the piano (*i.e.*, by decreasing the piano volume, the PDS-228CFX effectively makes the symphony louder than the piano). Moving the bar display toward P (pressing the [4] button) raises the volume of the piano relative to the symphony (*i.e.*, by decreasing the symphony volume).

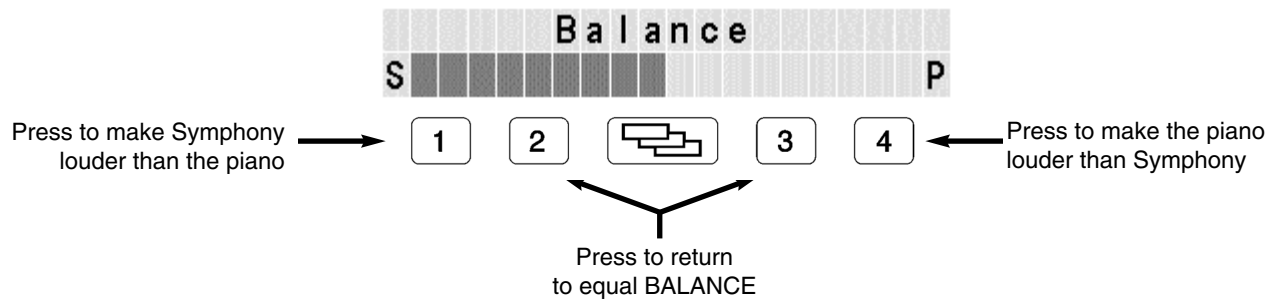

AUTO

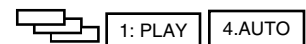

The AUTOPLAY function allows the system to begin playing when the PDS-228CFX is first turned on. When the box is turned off and then on again, the states of scope, song repeat, disk repeat, shuffle, and global repeat are retained.

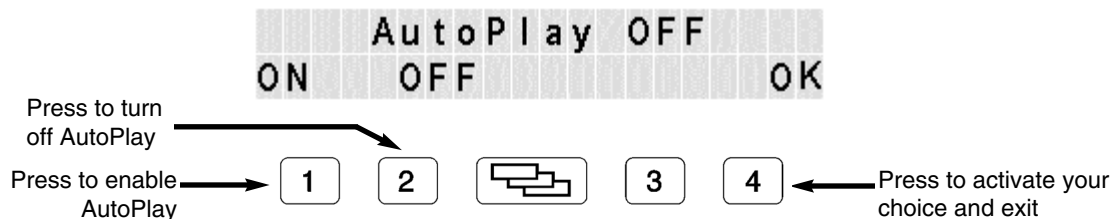

PIANO MUTE

2: KBRD 1: PMUTE

The PIANO MUTE function enables the user to silence the piano operation. Whether PMUTE is set to “On” or “Off,” Symphony sound will continue playing. (When PMUTE is set to “On,” the display will show “PMUTE” in the lower left hand corner.)

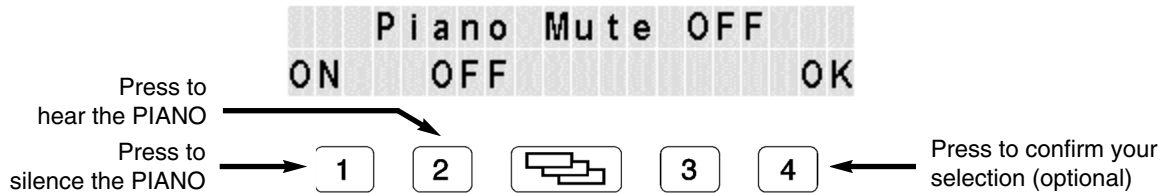

SPLIT

2: KBRD 2: SPLT

The SPLIT function allows you to mask (or disable) specific portions of the keyboard from playback operation. This makes it possible for the user to silence a particular part of the music while playing the other part manually. However, in PianoDisc systems with the SymphonyPro option, the accompanying orchestral music is unaffected by the SPLIT command.

Note: This function is accessible only from the front panel of the PDS-228CFX. It is not accessible through the PDS-228CFX IR remote control.

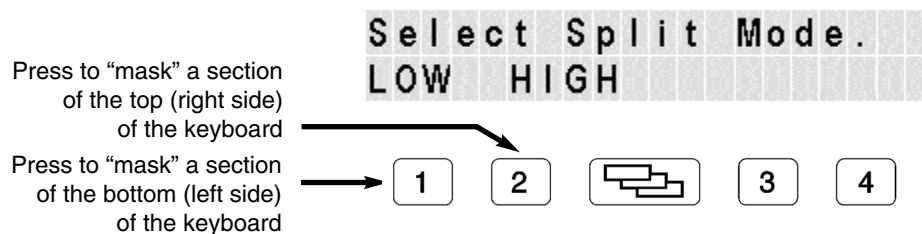

Setting The Split Point

After accessing the SPLIT function, select a high or low split by pressing the button under “HIGH” or “LOW”. A new window will display as shown below.

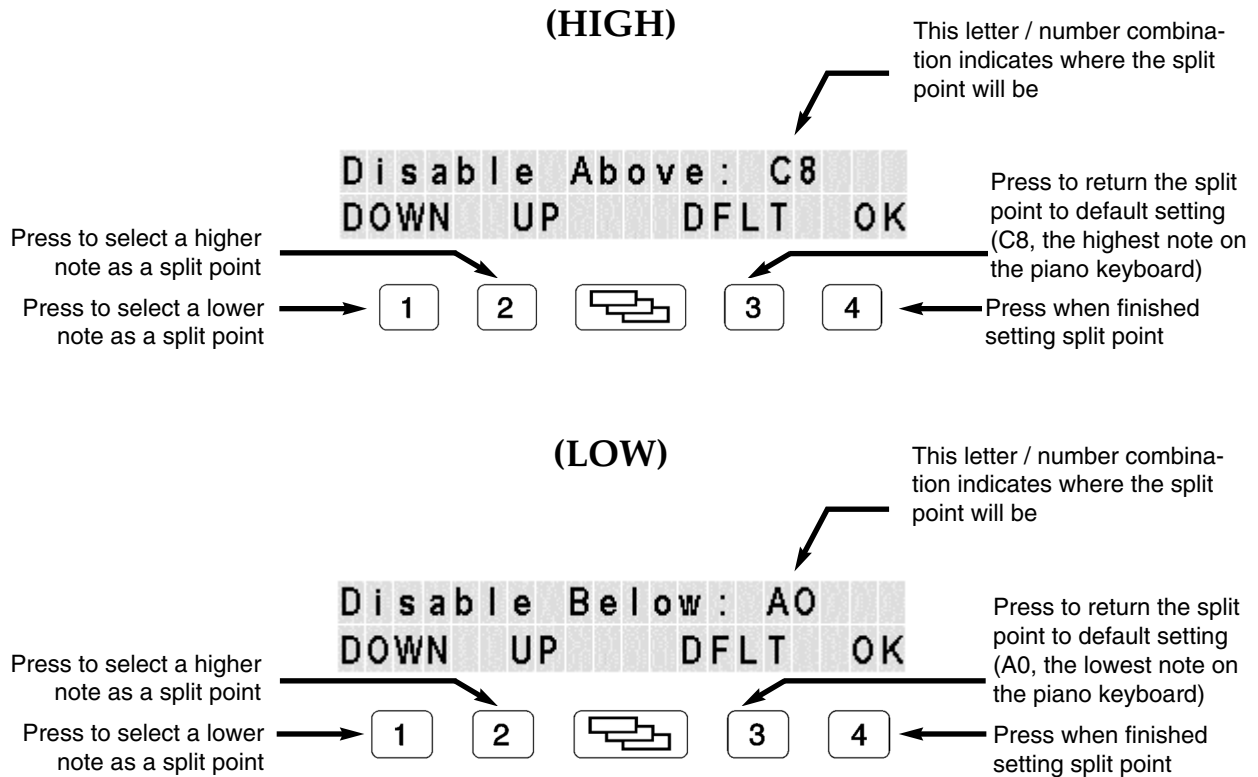

Pressing and holding the button below “DOWN” or “UP” will cause the displayed note to scroll upward/downward, and releasing it will select the displayed pitch as the split point. If you have the PianoDisc Record option on your piano, you may simply press the key above/below which you would like playback to be disabled. (This is not available during playback.) The display will immediately change, indicating the note that you pressed.

Undoing A Split

The PianoDisc system will “remember” that you have masked a portion of the keyboard, even if it has been turned off and powered up again.

To undo the split, first access the SPLIT function. Select “HIGH” for the right hand side or “LOW” for the left hand side of the keyboard. Press DFLT [3] (default) then OK [4] to confirm the selection. If both “HIGH” and “LOW” have been split, you must repeat this procedure for both splits to enable all notes. You may also reset both splits (and other system parameters) by restoring the default settings.

ACCOMPANIMENT



The ACCOMPANIMENT mode allows a pianist with the PDS-228CFX system to “accompany” his or her performance with any sound from the SymphonyPro module or from an external tone generator. By selecting ACCOMPANIMENT mode, you can choose from all 128 General MIDI presets available, allowing you to enhance and vary your performances by adding various background sounds. Only one sound at a time can be selected and used with this feature.

In order to use ACCOMPANIMENT mode as a performer, you must have the PianoDisc Record option installed on the piano. Since you will also need a source for the ACCOMPANIMENT mode sounds, we recommend our SymphonyPro Option. (Or, you could use an external tone generator; see page 21, “Using an External Tone Generator.”) Finally, a set of amplified speakers must be attached to the PDS-228CFX, or to the external tone generator.



Changing Sounds While in Accompaniment Mode

Once the ACCOMPANIMENT mode window is displayed, sounds from the instrument named on the display will “accompany” any notes that are played on the piano, whether by a performer or when playing a PianoDisc Music Library diskette. While the ACCOMPANIMENT mode window is displayed, you may select sounds from all 128 General MIDI presets to “accompany” the piano.

To select instrument sounds:

1. On the front panel, the [1] and [4] mode buttons will scan all the selections in order (backwards and forward, respectively).
 - Press [1] and release to select the previous instrument.
 - Press and release [4] to move forward and select the next instrument.
 - Press and hold either the [1] or [4] button and the display will move rapidly through the instruments in the respective direction.

Scrolling will stop when it has gone full circle (number 1 or 128 is reached). To continue, release, then press and hold either button again. Release the held button when the name of the instrument you want is displayed on the screen.

2. To select instruments with the *PDS-228CFX Remote*, use the Instrument [<<] [>>] buttons.

If you know the instrument number (patch numbers in MIDI terminology) and are in ACCOMPANIMENT mode, enter the desired instrument number on the numeric keypad on the PDS-228CFX remote control, then press the SELECT button.

Experiment with the various instrument sounds to find the ones that best compliment the piano performance.

Playing Diskettes While In Accompaniment Mode

PianoDisc Music Library diskettes (see note on following page) can be played while the PDS-228CFX control unit is in ACCOMPANIMENT mode. You may engage (and disengage) the ACCOMPANIMENT mode at any time. Also, you may change the “accompanying” sound, as well as any parameter or function at any time, even while a song is being played.

If you leave the PDS-228CFX in ACCOMPANIMENT mode, you will continue to hear the “accompanying” instrument throughout all the songs played, until you exit ACCOMPANIMENT mode.

Advancing Songs While in Accompaniment Mode

You can **switch songs** *while* remaining in ACCOMPANIMENT mode by using the [SCAN <<] and [SCAN >>] buttons. Press and release [SCAN>>] to advance to the next song. Press and release [SCAN<<] to go back.

Exiting Accompaniment Mode

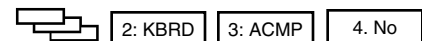

To exit ACCOMPANIMENT mode, you can use the stop button (on either the front panel or the remote). Pressing the stop button once stops playback, the second time (wait for the screen to display the instrument selection) disables ACCOMPANIMENT mode. Or you can use the flow diagram shown above.

You can also *toggle* ACCOMPANIMENT mode by pressing ACMP on the remote control.

Using an External Tone Generator

Since the PDS-228CFX is a General MIDI device, another General MIDI tone generator may be used with the PDS-228CFX for ACCOMPANIMENT mode.

To use an external tone generator with the PDS-228CFX you must have a tone generator with its own power supply and a MIDI cable. Plug the MIDI cable into the SYNTH OUT port on the back panel of the PDS-228CFX control unit and into the MIDI IN port

of the external tone generator. The audio outputs from the tone generator are now providing the “accompanying” sounds, so they must be hooked to an amplification system, such as a home stereo or a pair of amplified speakers.

Once everything is connected and ACCOMPANIMENT mode is activated, the system will operate as described in the previous sections. To change the “accompanying” sound, select another instrument in the ACCOMPANIMENT mode window of the PDS-228CFX. You may also change sounds directly on the external tone generator.

If you hear no “accompanying” sounds, verify that the external tone generator is not set to ignore messages transmitted on channel 1 (consult user manual). Patch changes and note information are transmitted to the external tone generator on MIDI channel 1.

Note: Accompaniment mode is not available during playback of Standard MIDI File songs.

EDUCATION



The EDUCATION function is used to set the MIDI channels for the “Left” and “Right” hand parts with Standard MIDI File software designed for acoustic piano playback. Pressing the PRODUCER button allows the user to choose left and right hand parts while playing a Standard MIDI File diskette. The channels **MUST** be set correctly before using the producer feature. The default is channel 3 for Left Hand Piano part and channel 4 for the Right Hand Piano part. Yamaha® educational type software will automatically work without adjusting these settings. To determine which MIDI channels the education parts are located on, read the manuals and documentation which accompany the purchase of commercial educational software for more information.

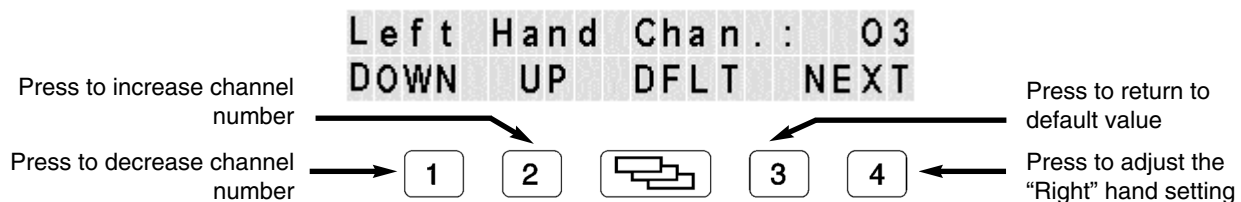

Note: Channel 10 is reserved for the drum track and should not be used. Also, do not set the left or right hand part to the same channel. If you wish to toggle the left and right hand piano parts on the same channel, use the piano toggle function. See page 69, Appendix D for more information on education.

DISK REPEAT



The DISK REPEAT function allows for the repeating of the entire diskette. After you press the [1] button (DISK), the display will give the option of turning the DISK REPEAT function ON or OFF (press [1] or [2]). Pressing the [4] button is optional: once the selection (ON or OFF) is made, it will be saved and the screen returned to the song title display. When DISK REPEAT is on, "DiskRp" will appear in the lower left corner of the display. DISK REPEAT will continuously repeat a disk until it is turned off or another function is selected.

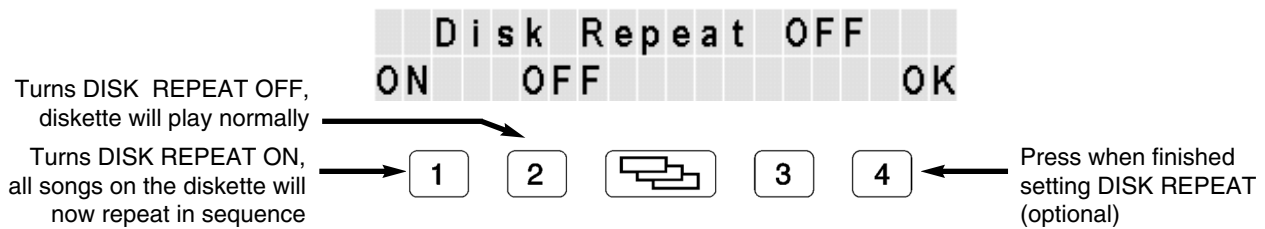

Note: When DISK REPEAT is turned "on," SONG REPEAT, SHUFFLE and GLOBAL REPEAT are automatically turned "off."

SONG REPEAT



The SONG REPEAT function allows for the repeating of a single song. After you press the [2] button (SONG), the display will give the option of turning the SONG REPEAT function ON or OFF (press [1] or [2]). Pressing the [4] button is optional. Once the selection (ON or OFF) is made, it will be saved and the screen returned to the song title display. When SONG REPEAT is on, "SongRp" will appear in the lower left corner of the display. SONG REPEAT will continuously repeat a song until it is turned off.

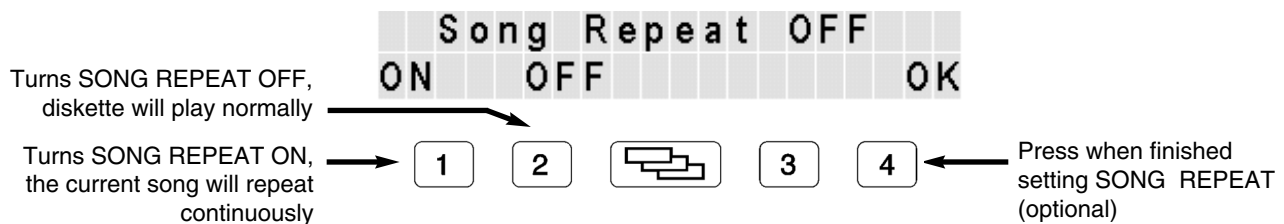

Note: When SONG REPEAT is turned "on," DISK REPEAT, SHUFFLE and GLOBAL REPEAT are automatically turned "off."

SHUFFLE



The SHUFFLE function allows the songs on a disk to be played in random order. As in all repeat functions, this feature is affected by both SCOPE and PRODUCER modes. See pages 25 and 32 for more information.

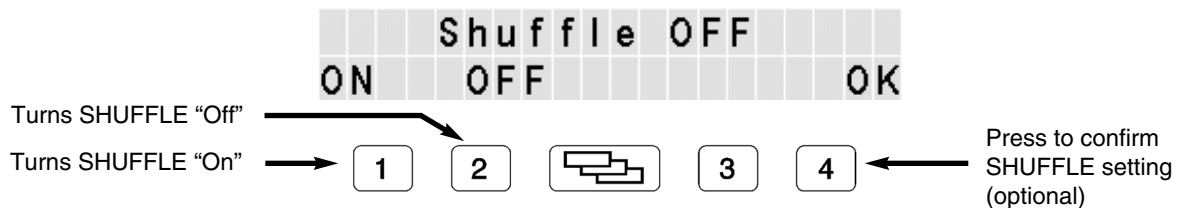

Note: When SHUFFLE is turned "on," DISK REPEAT, SONG REPEAT and GLOBAL REPEAT are automatically turned "off."

GLOBAL REPEAT



GLOBAL REPEAT offers the potential of uninterrupted playback circulating through all input sources (Diskette, PianoCD, and MX). If you're not using a PianoDisc CD player, you must begin CD playback manually.

To enable GLOBAL REPEAT:

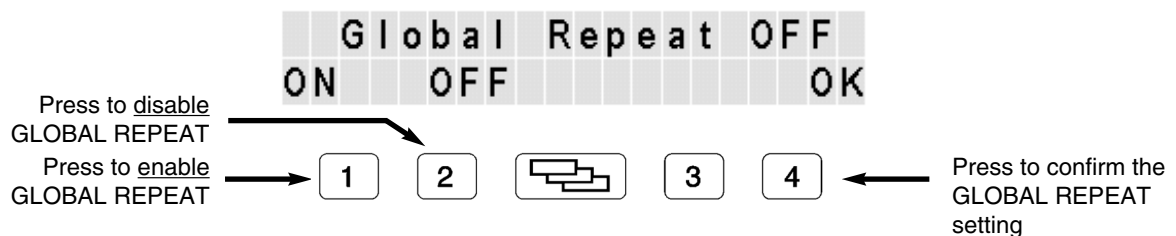

Note: When GLOBAL REPEAT is engaged, "GlobRp" will appear in the lower left hand corner of the display. This feature is affected by both SCOPE and PRODUCER modes.

SCOPE

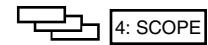

The SCOPE function allows the user to choose the range of playback from a disk. “Norm” is the setting for most common uses (and is the default). Under this setting, playback continues through all songs on a disk, stopping when it reaches the disk’s end (unless a REPEAT function is enabled).

To play a single song, then stop (avoiding automatic consecutive playback of all tracks on the disk), set SCOPE to “One.” Thus, when any song is finished playing, playback will stop with the next song cued (poised for play, with its title displayed). The user must press [PLAY] for each cued song to resume playback.

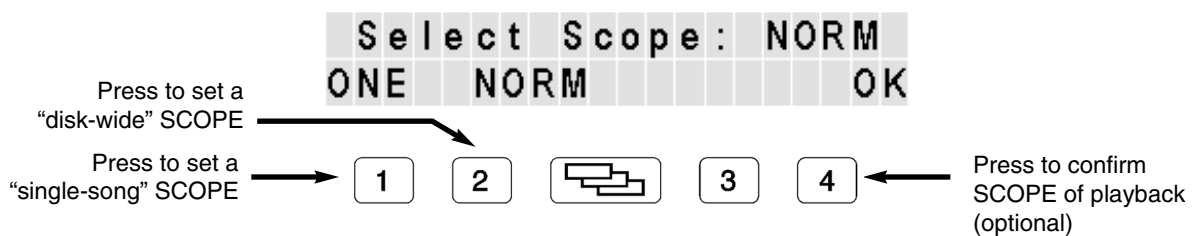

Mode Page #2

SYNC



The SYNC function permits adjustments in timing so that the piano notes coincide with those of the symphony option. This allows the user to make minor adjustments to achieve good synchronization of the music. Decreasing the SYNC by pressing the [1] button will move the symphony backward in time (makes the symphony play earlier relative to the piano). Increasing the SYNC by pressing the [4] button will move the symphony forward in time (makes the symphony play later relative to the piano). Generally, the lower the volume is set, the higher the SYNC should be set.

Note: The default SYNC value will vary depending on the type of disk currently in the drive. While your adjustments are remembered between disk changes, an offset will be automatically added or subtracted from the SYNC value to compensate for the disk type. In *MX* mode, this adjustment is made automatically on a song-by-song basis.

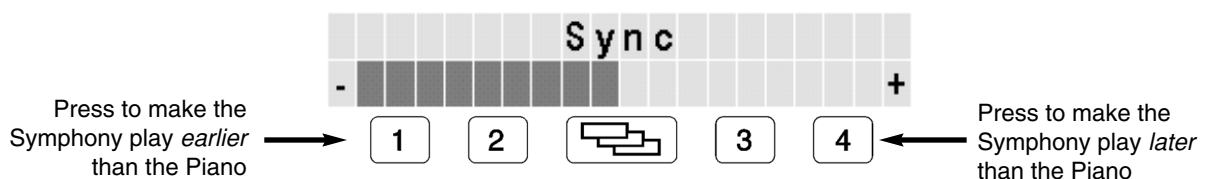

MIDI IN

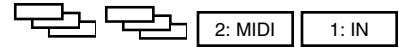

The MIDI IN function will select either the Record Option (PIANO) or an external source (MIDI). See additional information under the “RECORD” sub-section.

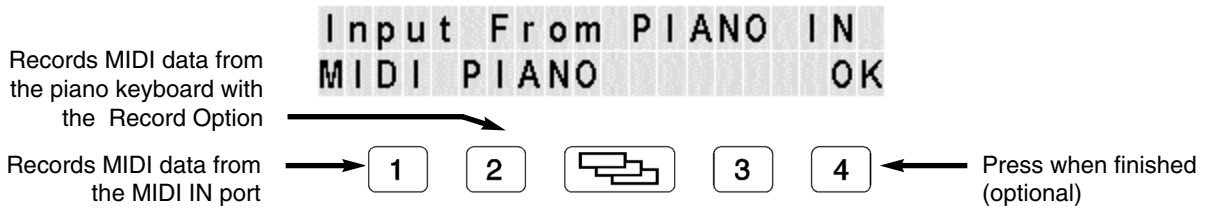

MIDI OUT

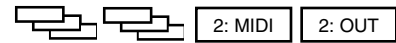

The MIDI OUT function allows the user to toggle the PIANO OUT, SYNTH OUT, and MIDI OUT ports On and Off. Toggle the state of the desired port by using the [1], [2], or [3] button. Press the [4] button to OK (optional). The MIDI output configuration will be stored in memory even when the PDS-228CFX is shut off.

Note: The normal PDS-228CFX MIDI output mode is PIANO OUT On, SYNTH OUT On, and MIDI OUT On (regardless of whether or not the PDS-228CFX is equipped with the internal synthesizer/instrument module).

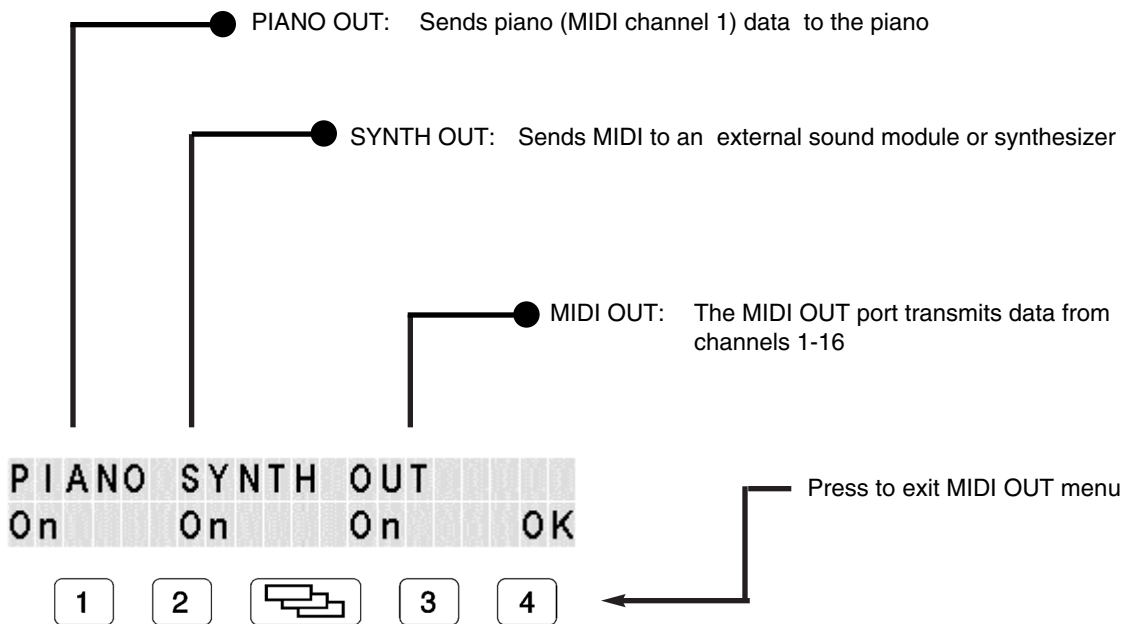

REDIRECT

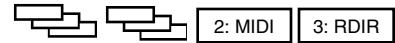

The REDIRECT function is typically used by advanced operators of the PianoDisc system who are integrating their PianoDisc into a MIDI studio setup, or by those who want to listen to the PianoDisc Music Library diskettes on another instrument, such as an electric keyboard.

Note: Using this function with an acoustic piano fitted with the PianoDisc system can disable the playback on your piano.

This function allows you to redirect the flow of filtered MIDI information from the “To Piano” port to the MIDI OUT port. (This can be useful if you are attempting to extract MIDI data from a diskette of music you have recorded into another MIDI device, such as a sequencer.)

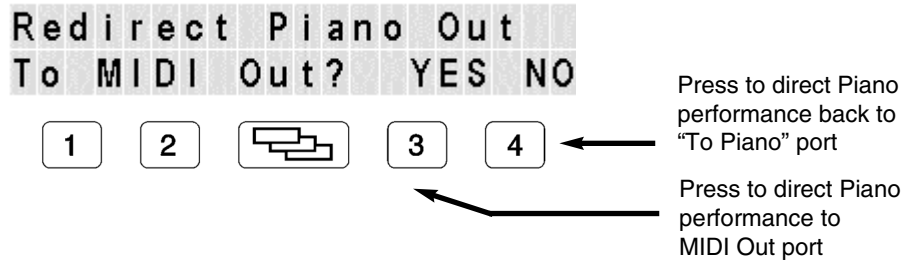

Note: REDIRECT does not work in CD mode. In order for REDIRECT to work, the MIDI OUT port must be turned on. Ensure that it is set to ON by following the instructions in the MIDI OUT sub-section in this guide (under FLOPPY DISK Mode).

PASSTHROUGH

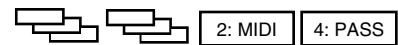

The PASSTHROUGH function is typically used by advanced operators with a sequencer or other external MIDI device. This function permits one to pass MIDI data through the PDS-228CFX MIDI IN port and play it on the PianoDisc system (Piano Ch.1, Synth Ch. 2-16). (See *Appendix G*, pg.73 for information on attaching cables to the PDS-228CFX.)

Passthrough Mode
(Press STOP To Exit)

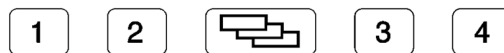

SOURCE

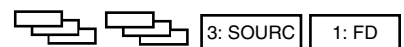

This menu item enables you to choose your playback source. To play from (or record onto) a diskette, go to the SOURCE button, and select FD.

Select Source: FD
FD CD MX OK

Press to select CD as the active source for playback

Press to select FLOPPY DISK as the active source for playback

Press to select MX as the active source for playback

Press to confirm your selection of the active source (optional)

DEFAULT



The DEFAULT function will reset FLOPPY DISK mode and MX mode parameters to their factory settings.

Restore Default Settings? NO YES



Press to maintain current settings.

Press to restore to factory settings.

Mode Page #3



The third MODE page presents a group of disk-related functions: ERASE, NAME, FREE, and FORMAT. These functions are not necessary for normal playback operation of the PDS-228CFX, and should be used only when recording new music and customizing diskettes.

Note: These disk functions work only with PianoDisc diskettes and are not available for other formats.

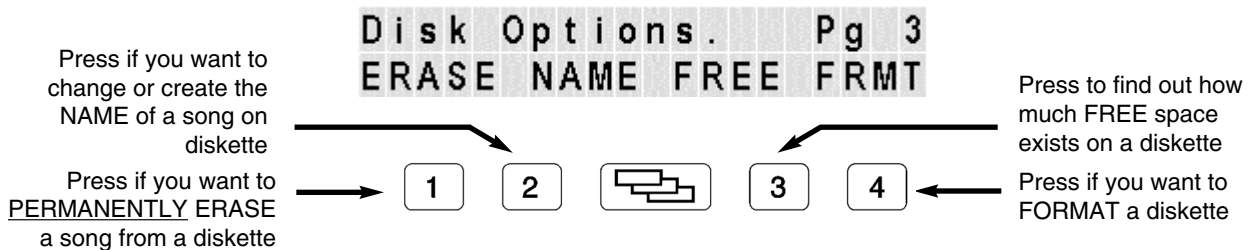

ERASE

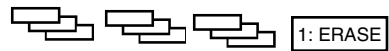

The ERASE function is used to delete a song permanently from a diskette. To remove a song, select ERASE from the DISK sub-menu. Use the [SCAN] buttons to select the song to be erased; then press OK. The PDS-228CFX will then ask for confirmation of the song to be erased. Choosing YES will permanently erase the song from the diskette, while pressing NO will exit from the ERASE function.*

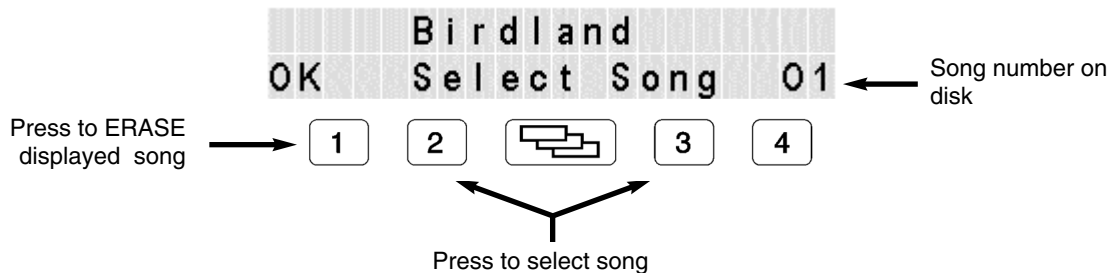

* Or, press the STOP button to exit from the ERASE function without erasing a song.

NAME

2: NAME

The NAME function allows the user to name any song, up to 20 characters long. Select NAME from the third Mode Page, choose the song to be named by pressing the [SCAN <<] and [SCAN >>] buttons, and then press OK. The naming screen will then be displayed.

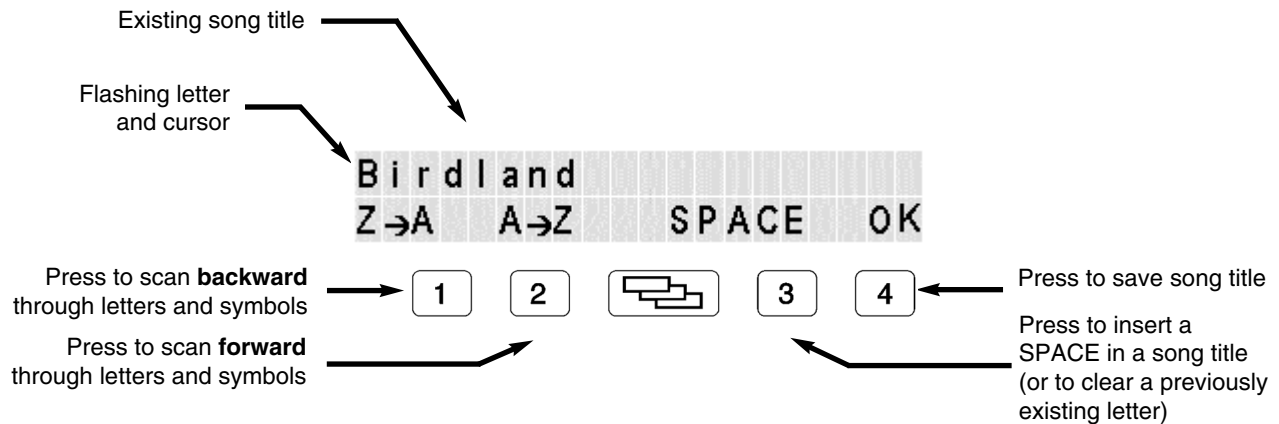

- Press the [SCAN >>] button to move to the next character in the song title, the [SCAN <<] button to move backwards.

Many characters other than the alphabet are available (scan through these using the [1] and [2] buttons).

- Characters can be “erased” by replacing them with spaces. This is especially useful if the new name is shorter than the old name, or if the new name contains spaces where the old one contained characters. Press [3] to replace a pre-existing character with a SPACE.
- If you wish to cancel (exit without saving any changes to the song title), press the STOP button to exit the NAME function.
- When the new song title has been completed, press OK (the [4] button) to save the new name on the disk. The song title will be saved exactly as it appears on the display.
- Since the new song name will be centered automatically on the main display, do **not** center it manually while creating the NAME.

Note: For an alternate naming procedure, useful when recording from an external sequencer, see “System Exclusive Messages” (*Appendix B, pg. 65*).

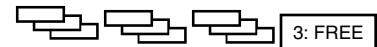
FREE

The FREE function will display how many bytes are free to record songs on a diskette. Low-density diskettes are formatted to allow up to 696K bytes of song data. High-density diskettes are formatted to allow up to 1392K bytes of song data. Before recording a piece, it may be wise to affirm that there is sufficient space with this function.

```
466K Bytes Free
Press STOP...
```

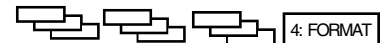
**FORMAT**

The FORMAT function initializes a 3.5 inch high-density or low-density diskette into PianoDisc format so that it may be used for recording and playback on the PDS-228CFX.

CAUTION Formatting a floppy diskette completely erases any information on the diskette. Be certain that the diskette is the correct density. The write protect notch **MUST** be closed to format.

To Format A Current PianoDisc Diskette:

If the diskette was already formatted for PianoDisc, insert the disk and access the format function. Select the density of the disk by pressing the appropriate key below the value (High Density: 1.44M, Low Density: 720K). Press the button below “OK” and then “YES” to continue.

To Format Other Disks (any non-PianoDisc pre-recorded diskette):

Insert a previously formatted PianoDisc diskette. Access the format function. Select the density of the disk by pressing the appropriate key below the value (High Density: 1.44M, Low Density: 720K). When prompted, eject the PianoDisc diskette and place the disk to be formatted in the floppy drive. Press the button below “OK” and then “YES” to continue.

Front Panel Functions

PRODUCER

P

The PRODUCER TRACK function permits one to customize diskettes by specifying which songs are to be played and in what order. Up to 99 songs may be chosen and a song may be repeated as often as desired. Once a PRODUCER TRACK is programmed and saved, it will remain on the diskette.

To play a diskette with a PRODUCER TRACK, insert the diskette, press the [P] button, and then press [OK]. When the PRODUCER TRACK is controlling playback, the green light next to the PRODUCER button will remain lit.

Pressing the [P] button toggles PRODUCER mode displaying the screen below, with a slight delay, giving you the option of manually overriding (or accelerating) the toggle by turning “off” (CANCEL) or “on” (OK). If you do not override the “toggle,” after a few seconds, the main song display window will re-appear, with PRODUCER toggled from its last state.

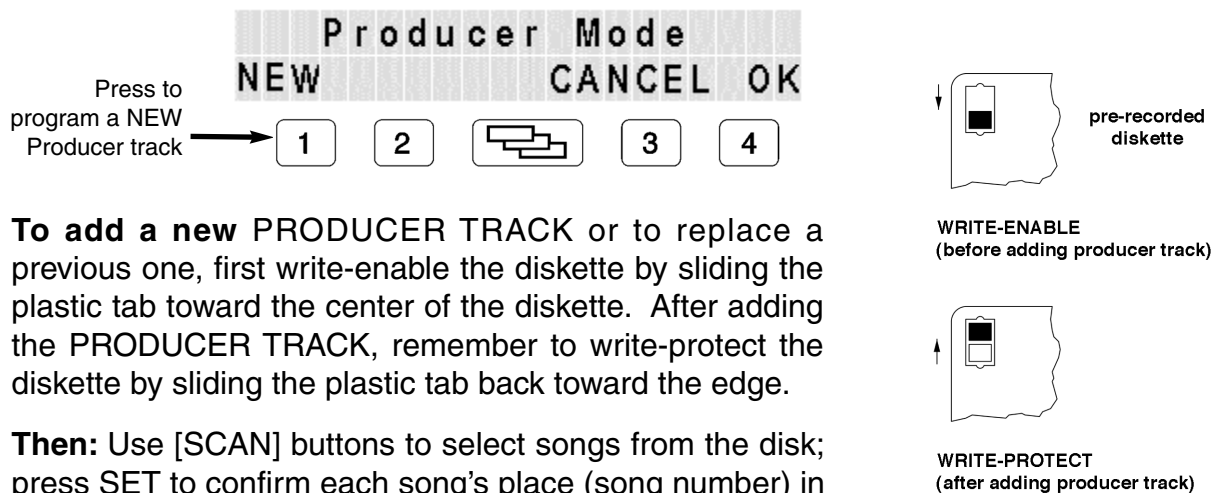

To add a new PRODUCER TRACK or to replace a previous one, first write-enable the diskette by sliding the plastic tab toward the center of the diskette. After adding the PRODUCER TRACK, remember to write-protect the diskette by sliding the plastic tab back toward the edge.

Then: Use [SCAN] buttons to select songs from the disk; press SET to confirm each song's place (song number) in the producer track sequence.

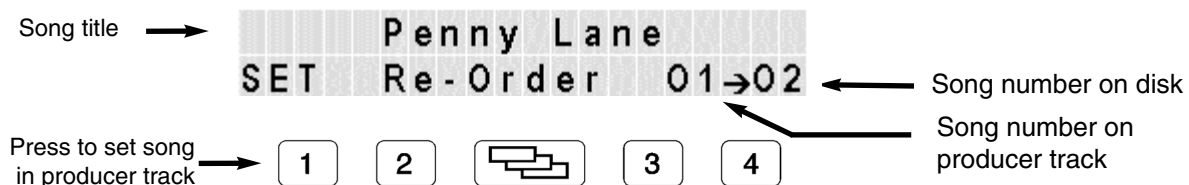

- To exit the PRODUCER menu without saving, press [STOP]
- To save your new PRODUCER TRACK on its diskette, press [PLAY] when finished setting up your programming (playback order). Then eject the diskette to flip the write-protect tab.

RECORD



The RECORD function is a one-pass, real-time MIDI recorder capable of saving MIDI data on all 16 MIDI channels (if used with an external MIDI Device). Any information (including note info, pitch bends, system exclusive data, etc.) sent to the PDS-228CFX can be recorded and saved on the diskette. Two possible sources of MIDI data for recording on the PDS-228CFX are the piano keyboard (Record Option installed) and an external MIDI device, such as a keyboard or a sequencer. To record a musical performance, first check to make sure that all MIDI cables have been properly connected.

Recording From the Piano Keyboard

With the Record Option, the piano keyboard becomes a MIDI controller, allowing musical performances to be recorded directly from the acoustic piano and replayed by the PianoDisc system.

Note: MIDI IN must be set to record from PIANO for this type of recording. Also, the piano performance *only* (MIDI channel 1) is saved to disk (i.e., no symphony parts will be saved for playback).

Recording From an External MIDI Device

To record from an external keyboard, computer, or any MIDI-equipped device, connect the MIDI cables as shown below. The PDS-228CFX will record MIDI data received at the MIDI IN port on all 16 MIDI channels.

Note: MIDI IN must be set to record from MIDI IN for this type of recording.

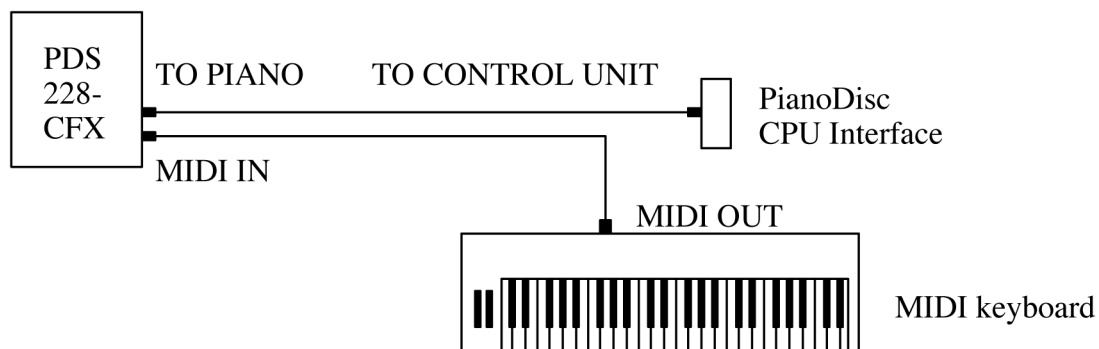

PDS-228CFX Recording Procedure

1. Insert a diskette into the PDS-228CFX. (The diskette must first be write-enabled.) It is not recommended that a pre-recorded diskette, such as one from the PianoDisc Music Library, be used for recording. It is better to record with a new diskette, formatted on the PianoDisc system. (See “FORMAT” sub-section for a description of the formatting process.)
2. To prepare the PDS-228CFX for recording, press the [RECORD] button. The display will change as shown below. The red light next to the RECORD button will begin flashing, indicating that the PDS-228CFX is set to begin recording MIDI data onto the diskette (or an *MX* library, with *MX* option) at the next command.

```

Ready To Record
metro SLOWER FASTER

```



Flashing red light indicates PDS-228CFX is prepared to start recording.

3. Now, you have the option of engaging the metronome (For use during recording or simply practicing.) If you do not wish to use the metronome, skip to step 4. To activate the metronome, press [1]. The display will change from “metro” (lower case) to “METRO” (upper case), and you will hear the metronome tick. To toggle metronome “off” press [1] again. To adjust the metronome tempo, use the [3] and [4] buttons.

```

Ready To Record
METRO SLOWER FASTER

```

Note: You will not hear the metronome unless you have the symphony option or an external tone generator. Neither the volume nor the sound of the metronome can be changed.

4. When you are ready to start recording, press the [RECORD] button again. If you have enabled the metronome, you will notice the metronome sound change to a standard metronome “tick” upon pressing [RECORD]. After a slight delay, the PDS-228CFX will begin saving incoming data to the diskette. If RECORD is initiated from within *MX*, data will be saved to the *active MX* library.

Note: You can also press the damper (rightmost) pedal to trigger recording.

When you have finished recording, press [STOP]. The new song and its number on the diskette will appear on the display. For more information on naming the newly recorded song, see the NAME sub-section.

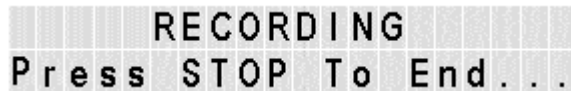



Red light will stay on, indicating that PDS-228CFX is recording MIDI data, if any.

Using Symphony Accompaniment While Recording

If your PDS-228CFX is equipped with the Symphony option, you can accompany your performance with an instrument while recording.*

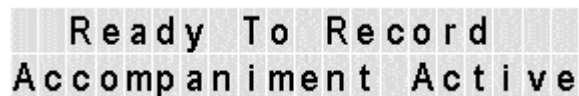
1. Enable Accompaniment mode (see ACCOMPANIMENT, pg. 20).
2. Choose your accompanying instrument using the [1] and [4] buttons.
3. To prepare for recording, press [RECORD]. The display will appear as shown below, and the red light adjacent to the [RECORD] button will begin flashing, indicating that the PDS-228CFX is set to begin recording MIDI data onto the diskette (or an *MX* library, with *MX* option) at the next command.



Flashing red light indicates PDS-228CFX is prepared to start recording.

4. When you are ready to record, press [RECORD] again.
5. When you have finished recording, press [STOP].

* **Note:** The accompanying instrument will **not** be recorded. Neither the accompanying instrument nor the volume can be changed. MIDI IN must be set to PIANO to use this feature.

Section IV

CD Mode

PDS-228CFX “CD Mode”

All PDS-228CFX units are equipped to play PianoDisc PianoCDs. These special CDs contain piano data as well as digital audio accompaniment (on selected titles). The use of digital audio allows the piano performance to be complemented by live orchestration and vocals. The following is a summary of the PDS-228CFX’s CD capabilities:

- Plays the piano and provides digital audio accompaniment (on selected titles).
- Reads PianoDisc PianoCDs.
- Reads standard audio CDs (without piano playback).
- Supports an external CD changer with a combination of PianoCDs and standard audio CDs (see page 45 for information about the AutoBypass feature).
- Supports up to 99 songs on each disc.
- Provides treble and bass tone controls.

PianoCD Benefits

The best way to play PianoDisc CDs is through an internal or external PianoCD player. You can also connect a standard CD player to your PDS-228CFX but some of the functionality of CD Mode is not available. The following is a summary of the features gained by using an internal or external PianoCD player:

- Full control of transport features (play/pause, stop/eject, scan and fast forward/reverse) from the front panel of the PDS-228CFX and the IR remote.
- Player piano awareness means that you can scan between songs, fast forward, or fast reverse without adversely affecting playback.
- AutoPlay and GlobalRepeat features can automatically start playback of the CD.
- Song number is displayed on the PDS-228CFX if an internal PianoCD player is installed. An external PianoCD player displays the song number on its own display.
- Direct song number selection via the IR remote.
- Shuffle is available from the front panel and IR remote when an internal PianoCD player is installed. An external PianoCD player supports Shuffle via the IR remote, or from the front panel of the PianoCD player.
- No need to adjust audio levels to make a PianoCD player compatible with PDS-228CFX.

Selecting CD MODE

C/F/X 2: CD

To play back from CD, press the SOURCE button. Repeat again until CD appears. After a slight delay, the letters **CD** will be displayed in the lower right hand corner. (For external CD units, the screen may look slightly different.)

The Mode Pages

Push the MODE button to display more functions than are immediately available on the PDS-228CFX front panel. The first page of functions (viewed by pressing MODE) contains SYNC, BALANCE, REPEAT and TRANSPOSE. The second page (viewed by pressing MODE again) contains MUTE, PIANO MUTE, SOURCE, and DEFAULT. The third page contains TREBLE, BASS, BYPASS, AND DEFEAT.

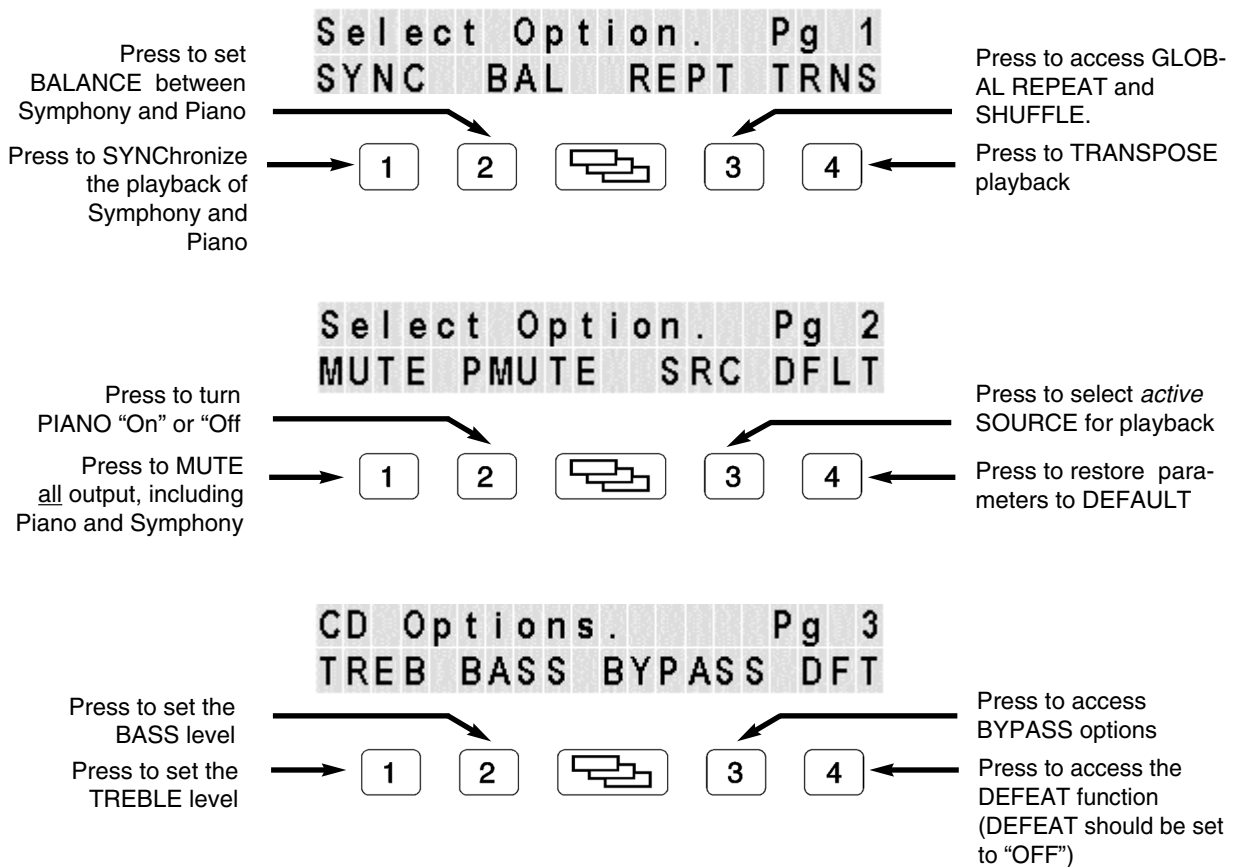

Mode Page #1

SYNC



The SYNC function permits adjustments in timing so that the tones of the piano coincide with those of the accompaniment. This allows the listener to make minor adjustments to achieve good synchronization of the music. Decreasing the SYNC, by pressing the [1] button, will move the piano forward in time (makes the piano play earlier relative to the accompanying music). Increasing the SYNC, by pressing the [4] button, will move the piano backward in time (makes the piano play later relative to the accompanying music).

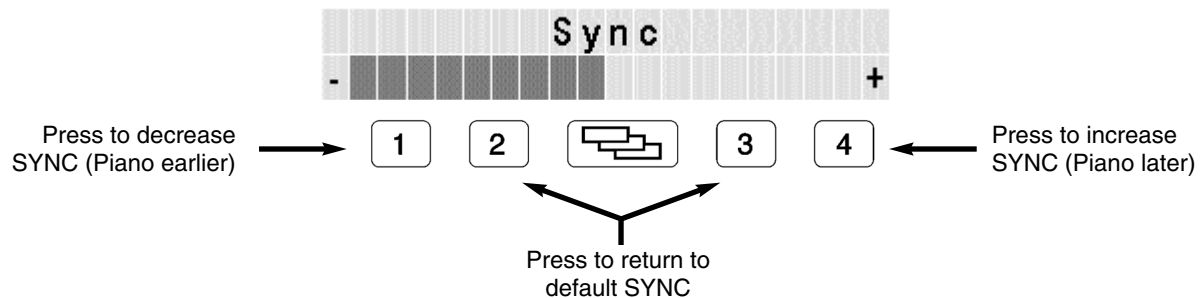

BALANCE



The BALANCE function controls the mix, or relative volumes, between the symphony and piano outputs of the PianoDisc system. Moving the bar display toward the “S” (by pressing the [1] button) raises the volume of the symphony portion of the music relative to the piano (*i.e.*, by decreasing the piano volume, the PDS-228CFX effectively makes the symphony louder than the piano). Moving the bar display toward P (pressing the [4] button) raises the volume of the piano relative to the symphony (*i.e.*, by decreasing the symphony volume).

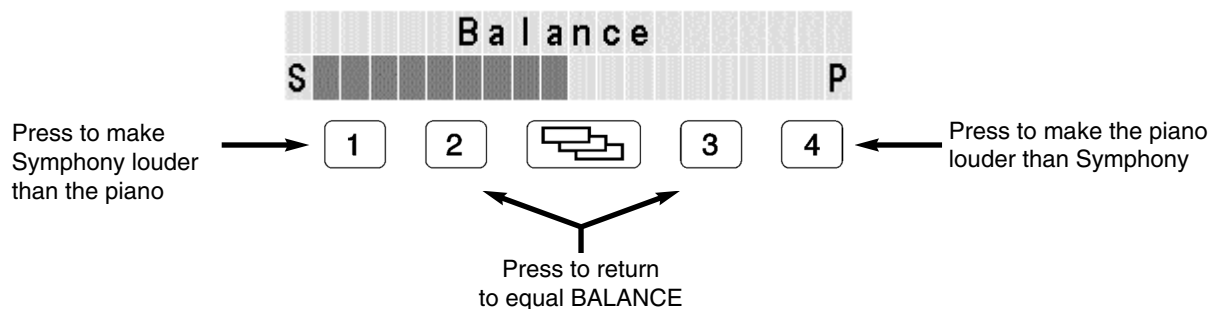

SHUFFLE



The SHUFFLE function allows the songs on a disk to be played in random order. The SHUFFLE function will also play songs continuously, and at random, until SHUFFLE is turned off.

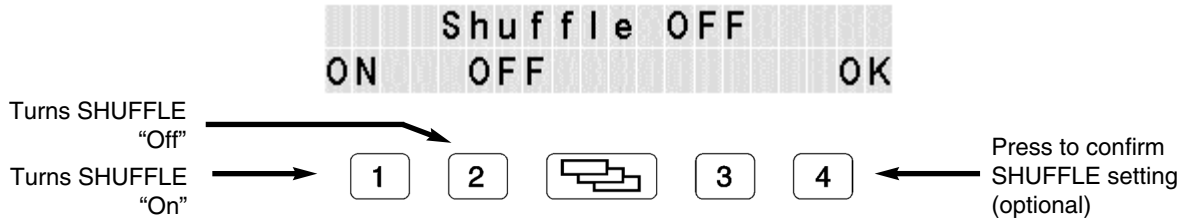

Note: When SHUFFLE is engaged, "Shuffl" will appear in the lower left hand corner of the display. GLOBAL REPEAT is automatically turned off.

GLOBAL REPEAT

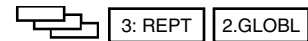

GLOBAL REPEAT offers the potential of uninterrupted playback circulating through all input sources (Diskette, PianoCD, and MX). If you're not using a PianoDisc CD player, you must begin CD playback manually.

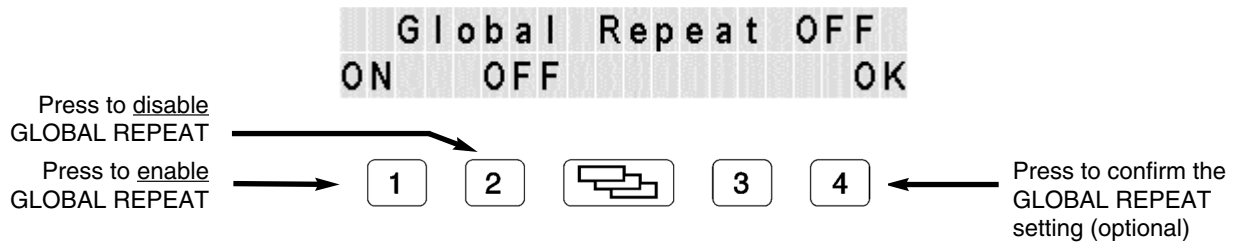

Note: When GLOBAL REPEAT is engaged, "GlobRp" will appear in the lower left hand corner of the display. SHUFFLE is automatically turned off.

TRANSPOSE



The TRANSPOSE function enables the user to change the key of a PianoDisc CD performance. You can change the pitch in half-step increments...up to two octaves in each direction (“up” and “down”), for a range of 4 octaves. Go to the TRANSPOSE screen, then use [1] and [4] to move the key “up” or “down” (respectively). Pressing either [2] or [3] will restore playback to the original pitch.

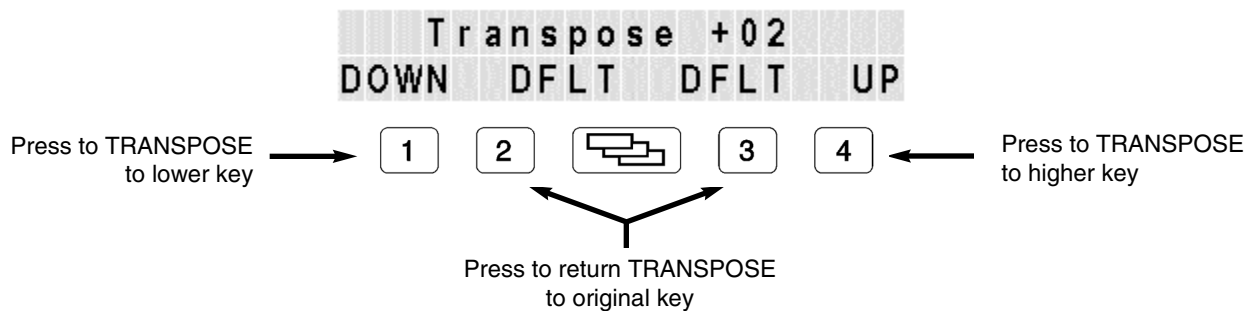

Note: If the CD being played contains an audio accompaniment, it will automatically be muted as you transpose “up” or “down.” When you reach *octave points* (-24, -12, 0, 12, 24), audio playback will resume. When the audio is muted, “TrMute” will be shown on the lower left corner of the display.

Mode Page #2

MUTE



The MUTE function silences all output of the PianoDisc system, both piano and accompanying music. After selecting MUTE, choose ON or OFF [1] or [2], then OK [4]. The display will show “Mute” when MUTE is ON.

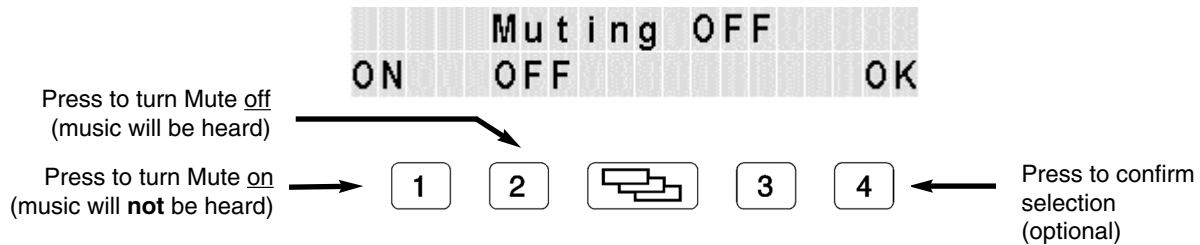

PIANO MUTE



The PIANO MUTE function enables the user to silence the piano operation. Whether PMUTE is set to “On” or “Off”, Symphony sound will continue playing. (When PMUTE is set to “Off”, the display will show “PMUTE” in the lower left hand corner.)

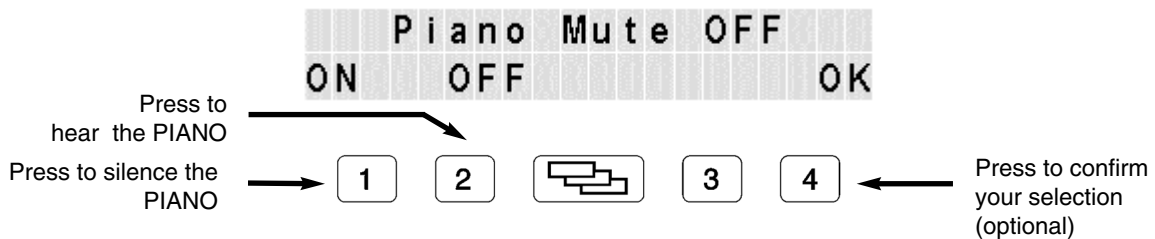

SOURCE

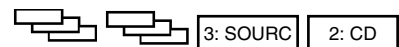

This menu item enables you to choose your playback source by using the mode buttons. You can also use the SOURCE button located on the front panel to choose FLOPPY DISK, CD or MX.

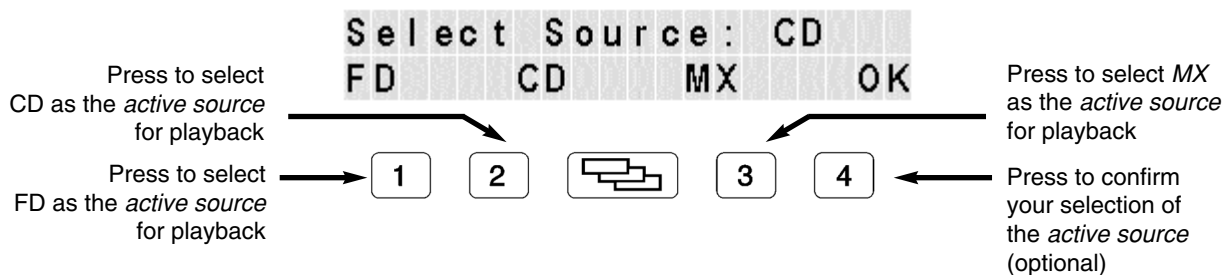

DEFAULT



The DEFAULT function will reset ALL CD mode parameters to their factory settings. Press NO [3] to keep current settings. Press YES [4] to restore to factory settings

Mode Page #3

Note: The Menu items listed below are specific to CD Mode.

TREBLE

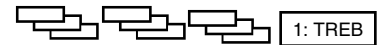

The TREBLE function adjusts accompanying music from the CD. The TREBLE may be decreased (by pressing the [1] button) down to -12dB. The TREBLE may be increased (by pressing the [4] button) up to +12dB.

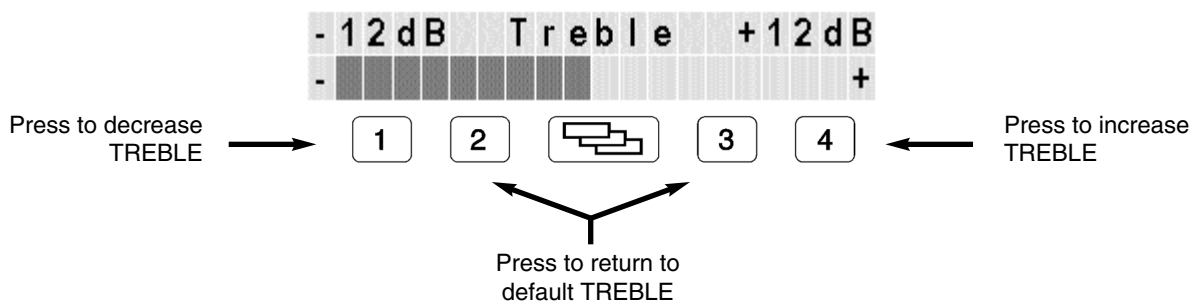

BASS

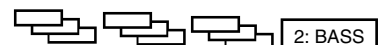

The BASS function adjusts accompanying music from the CD. The BASS may be decreased (by pressing the [1] button) down to -12dB. The BASS may be increased (by pressing the [4] button) up to +12dB.

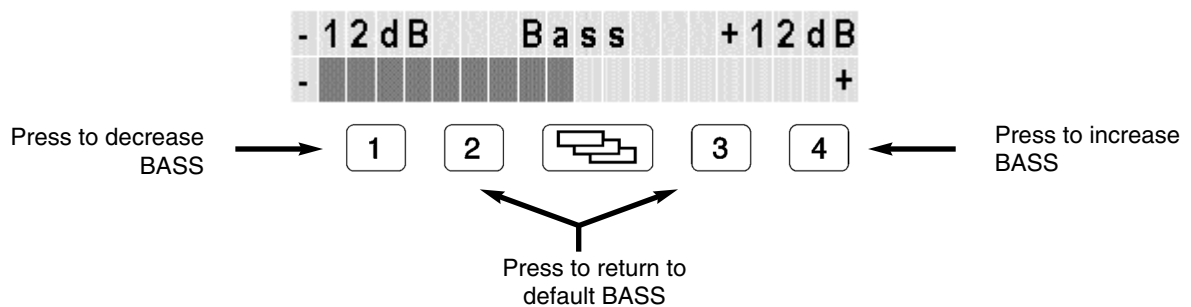

BYPASS

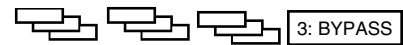

The BYPASS function allows both the left and right music channels of standard Compact Discs (CDs) to be passed directly through the PDS-228CFX system to the stereo speakers. When BYPASS is ON, the piano will not play. (When BYPASS is “On,” the indicator “Bypass” will appear in the lower left hand of the display.) BYPASS should never be engaged while playing a PianoDisc format compact disc, because doing so will send a high pitched squeal to the right channel of the stereo speakers. Set BYPASS to OFF during normal operation.

If you frequently switch between playing PianoDisc CDs and standard audio CDs—or, if you load a multiple “CD changer” with a combination of PianoDisc CDs and standard audio CDs—set BYPASS to AUTO [3]. The PDS-228CFX will dynamically “sense” the kind of CD which is playing, and will automatically switch to and from BYPASS mode according to the requirements of each disk.

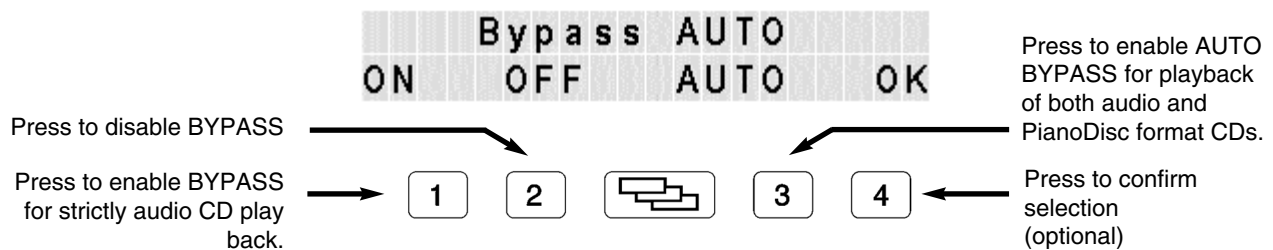

DEFEAT

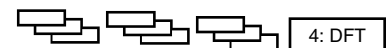

The DEFEAT function disables the normal operation of the CD mode. DEFEAT OFF allows the PDS-228CFX to process the loudness and duration of the notes to insure the best possible performance on the piano. Turning DEFEAT ON disables this adjustment, and should not be done for normal usage. Set DEFEAT to OFF for normal operation.

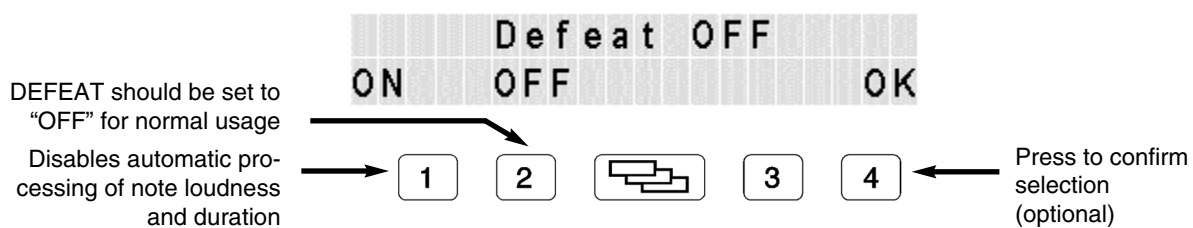

Section V

MX Mode

PDS-228CFX “MX Mode”

If your PDS-228CFX is equipped with the *MX* option, your PianoDisc system can provide hours-upon-hours of uninterrupted music. The *MX* Option has no moving parts, and uses flash technology to store music inside the PDS-228CFX. While *MX* comes with pre-installed music, you can also add your own songs. In addition, *MX* has many features that allow you to customize playback. The following is a summary of the PDS-228CFX’s capabilities:

- Contains 25 hours of pre-installed PianoDisc music.
- Plays the piano and the SymphonyPro (or external sound module).
- Reads PianoDisc songs.
- Reads PianoSoft™ songs.
- Reads Standard MIDI Type 0 songs.
- Reads educational Standard MIDI type 0 songs and allows the left hand, right hand, or both to be toggled.
- Records songs in PianoDisc format.
- Contains 12 libraries in the standard configuration.
- Stores up to 99 songs in each library.
- Stores approximately 2.5 megabytes (MB) of music in each library.
- Allows any combination of PianoDisc, PianoSoft, and Standard MIDI type 0 songs in the same library.
- Allows individual songs or an entire disk to be copied into a library from a floppy disk.
- Allows a customized playback order for each library (via Producer Mode).
- Allows entire libraries to be hidden.
- Allows playback from a single library, or across all libraries (see page 50 for more information about the SCOPE feature).

Selecting *MX* MODE

To play back from *MX*, press the SOURCE button. Repeat again until *MX* appears. After a slight delay, the letters *MX* will be displayed in the lower right hand corner with the current song number.

The Mode Pages

Push the MODE button to display more functions than are immediately available on the PDS-228CFX front panel. There are three pages. The first page of functions contains PLAY, KEYBOARD, REPEAT and SCOPE. The second page (press MODE again) contains SYNC, MIDI, SOURCE, and DEFAULT. The third page contains LIBRARY, NAME, FILE, and MASK.

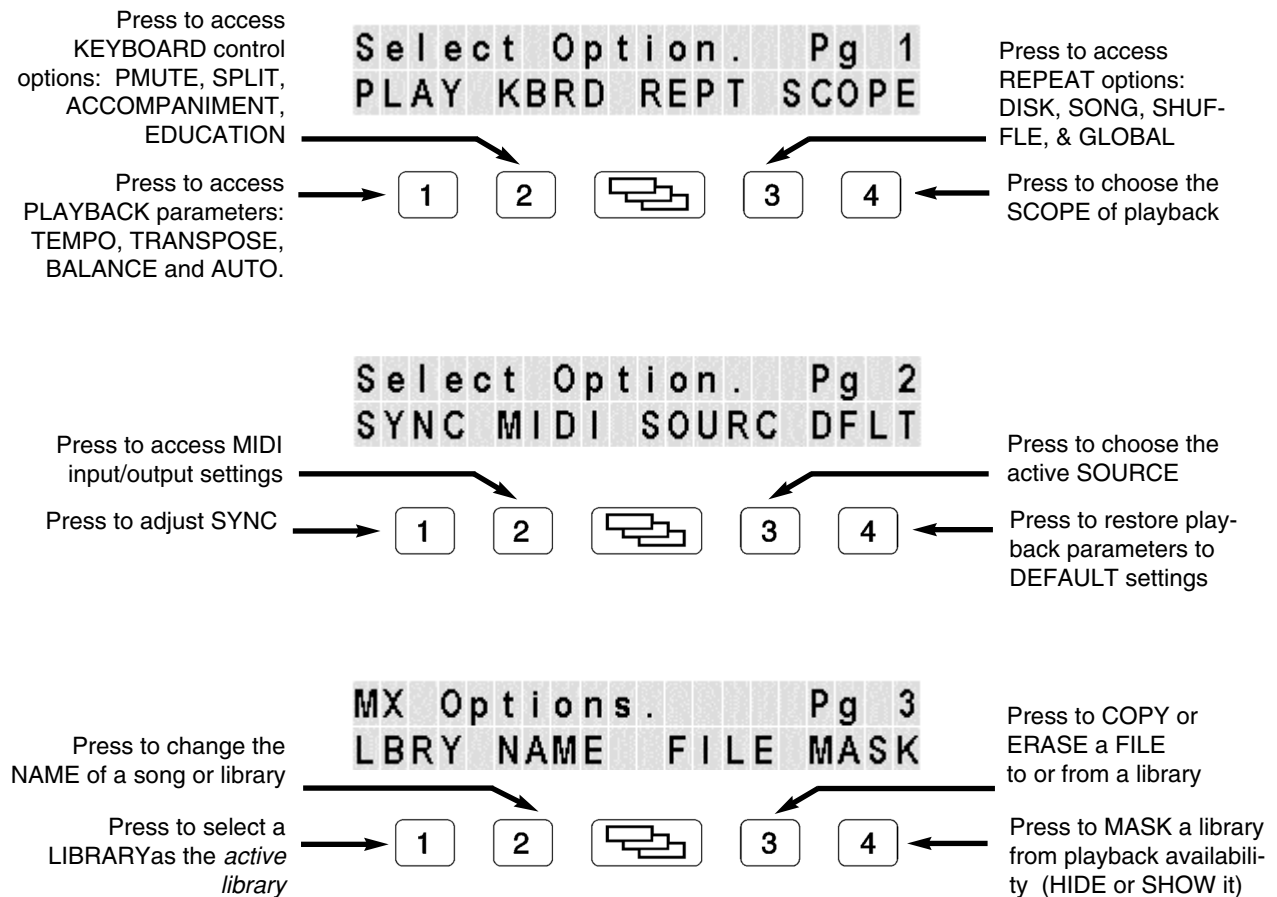

Enhancements to Mode Page 1

When the PDS-228CFX is in *MX MODE*, the first two mode pages, their sub-menus, and functions are nearly identical to those in *FLOPPY DISK mode*. For an explanation of these, see entire “*FLOPPY DISK Mode*” section, page 13.

SCOPE

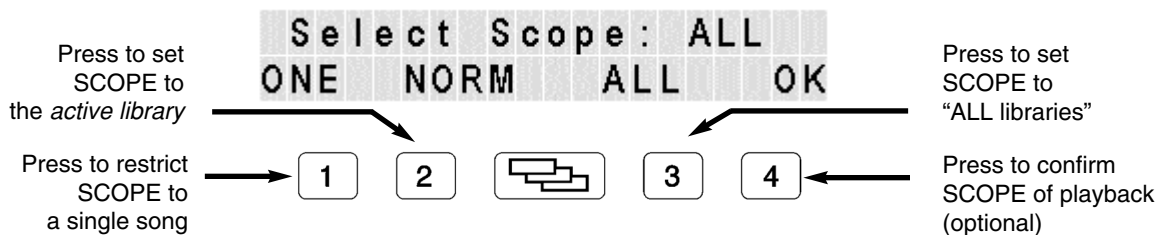
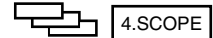

SCOPE is adapted in *MX Mode* to give you the ability to limit playback to either one song [1], the active library [2], or all libraries [3].

DISK REPEAT

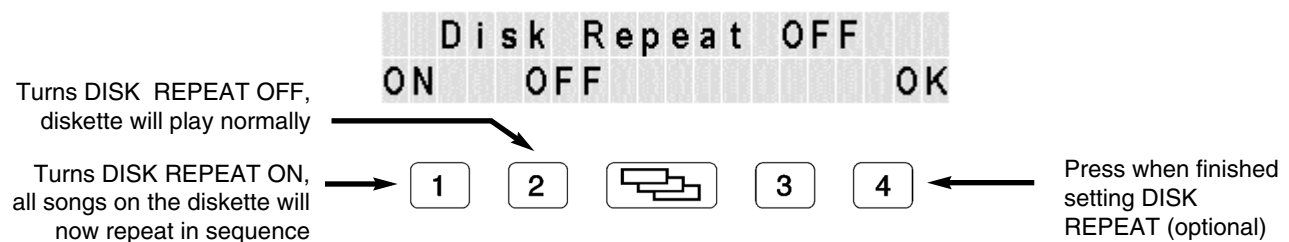

SHUFFLE



This option gains flexibility from the other custom playback features highlighted in this section. For instance, when SCOPE is set to NORM (current library), SHUFFLE will randomly play only the songs within the current library. However, if SCOPE is set to ALL, SHUFFLE will randomly play songs while advancing through all libraries.

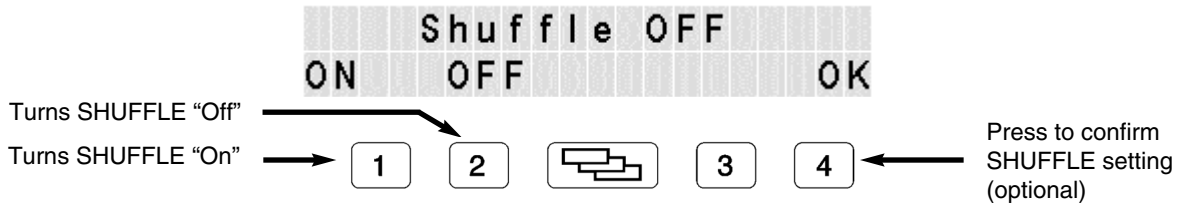

GLOBAL REPEAT



GLOBAL REPEAT offers our users the potential of uninterrupted playback circulating through all of their Input Sources (Floppy Diskette, PianoCD, and MX). This feature can be used with SCOPE to include all *MX* libraries or individual ones.

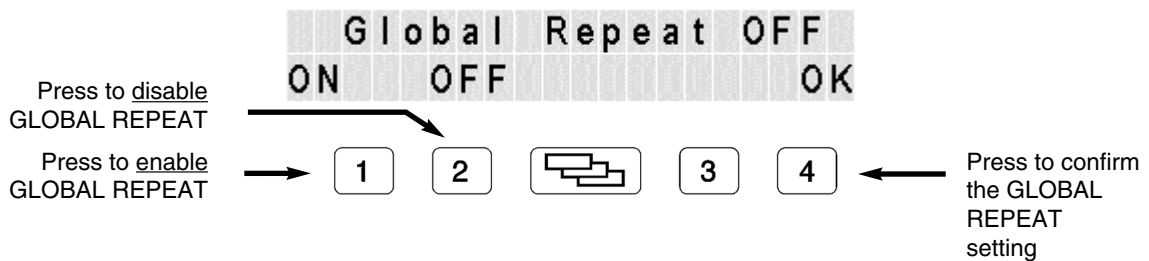

Mode Page #3

All the functions accessed through the third mode page are unique to the *MX*. Immediately below we will show you how to access and use them in basic ways. Then, we will show you how to combine them with those from the two general mode pages, to utilize the full capabilities of your *Music eXpansion* option.

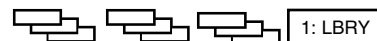

LIBRARY

This option lets you choose the active library. This is where your playback will start. Use the [SCAN] buttons [2] or [3] to scroll through the libraries. When you find the one you want, press [1] (OK) to make it the active library.

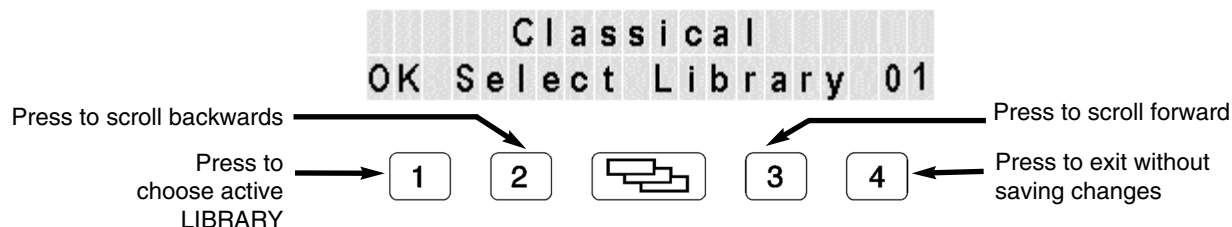

If SCOPE is set to NORM, the PDS-228 CFX will treat the active library as a disk, and your playback will be restricted to the active library; if SCOPE is set to ALL, playback will begin within the active library and continue through the available libraries. See pages 25 and 50 for more information on SCOPE.

NAME

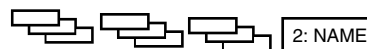

To NAME (or rename) a SONG, choose the [2] button. To NAME a LIBRARY, press [1]. Whether you are renaming a SONG or a LIBRARY, the remaining steps of this procedure are identical to using the NAME function in FLOPPY DISKETTE Mode.

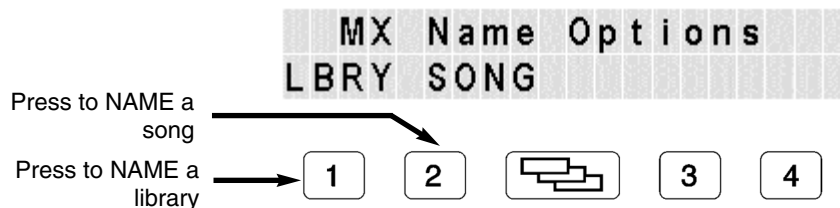

COPY



First, go to FILE:COPY. To COPY one song at a time from a diskette, choose SONG [2]. Use the familiar [SCAN] buttons to select the library you wish to COPY to, then select "OK" [1]. Next, select the song you wish to copy (again, use the [SCAN] buttons), and "OK" [1]. Finally, press [4] to OK the copying process.

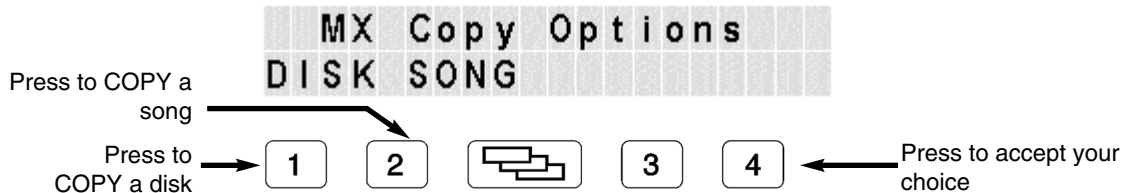

Or, you can copy an entire disk in one simple process. Choose FILE:COPY:DISK. Using the [SCAN] buttons, select the library you intend to COPY to, then "OK" [1].

Note: Copying an entire diskette may require a few minutes.
DO NOT interrupt this process!

ERASE



If you find a song in *MX* that you would like to omit from occasional playback, use the PRODUCER function, described in the PRODUCER sub-section.

To delete the song entirely, follow the steps below.

Select the library that contains the song to be erased. (See LIBRARY function, pg. 52, to choose an *active* library.)

- Press FILE [3] then ERASE [2].
- Press SONG [2] to erase one song at a time, using the [SCAN] buttons to find the song then press OK [1]. A warning message appears.

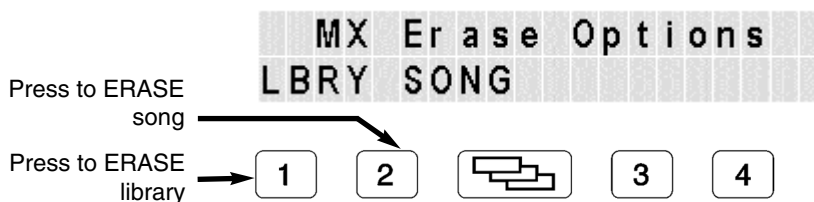

Note: Erasing an individual song may require a few minutes.
DO NOT interrupt this process!

You can empty an entire library. Select the library whose contents you wish to delete. Next, choose FILE:ERASE:LBRY. **Warning:** Be sure you are ready to permanently delete all contents of the Active Library before you answer YES [4]. Press NO [3] or, Press [STOP]! to avoid accidentally pressing button [4].

MASK

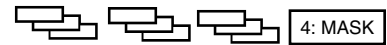

This option allows you to exclude certain libraries from playback programming. Hiding a library causes the *MX* to treat it as if it doesn't exist.

- Press HIDE [1] to temporarily disable a library from playback. Use the [SCAN] buttons to find the library you wish to forget or feature.
- Press SHOW [2] to re-enable the library for playback.
- Press RESET [4] to reset all libraries to SHOW.

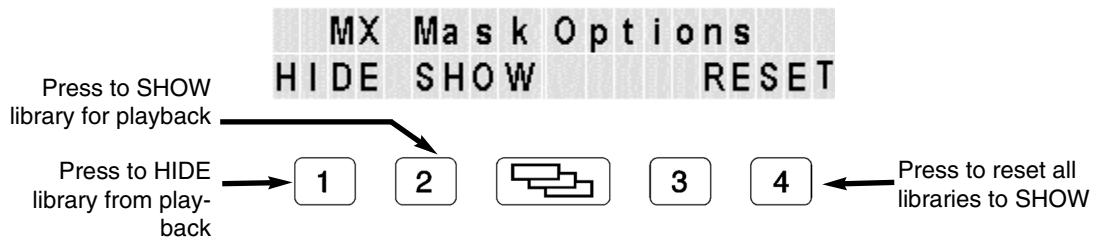

Note: When disabling libraries, *MX* will preserve the availability of the first library (it cannot be masked).

PRODUCER

P

To master the basic capabilities of the PRODUCER function, refer to page 32 of FLOPPY DISK mode for step-by-step instructions.

The *MX* PRODUCER function differs from that of FLOPPY DISK Mode by...

1. Allowing you to program non-PianoDisc songs in your PRODUCER Track.
2. Enabling you to create an independent PRODUCER Track for each library.

Enhance Your Listening Experience by Combining Functions.

You can program song lists (each library is allowed its own PRODUCER track) for various libraries and play only those selected songs. You can also restrict playback to a single library's songlist [SCOPE:NORM] or you can playback from all libraries' song lists [SCOPE:ALL]. Add REPEAT:SHUFFLE and PianoDisc's MX will randomly play through only the selections you chose on your list(s) from either a single library or all libraries, depending on the [SCOPE] setting.

You can also MASK out any libraries whose songs you want to exclude from playback (when in SCOPE:ALL). MASK:HIDE removes a library from the menu and temporarily disables it from playback.

For example: Perhaps you have a library of "Christmas" music, which you wish to exclude from ALL playback after December 25. Simply MASK:HIDE it until next season; then, choose MASK:SHOW, and select "Christmas." It now becomes available again for playback. The PRODUCER TRACK remains intact with the same set of songs.

Section VI

Remote Control

Remote Control

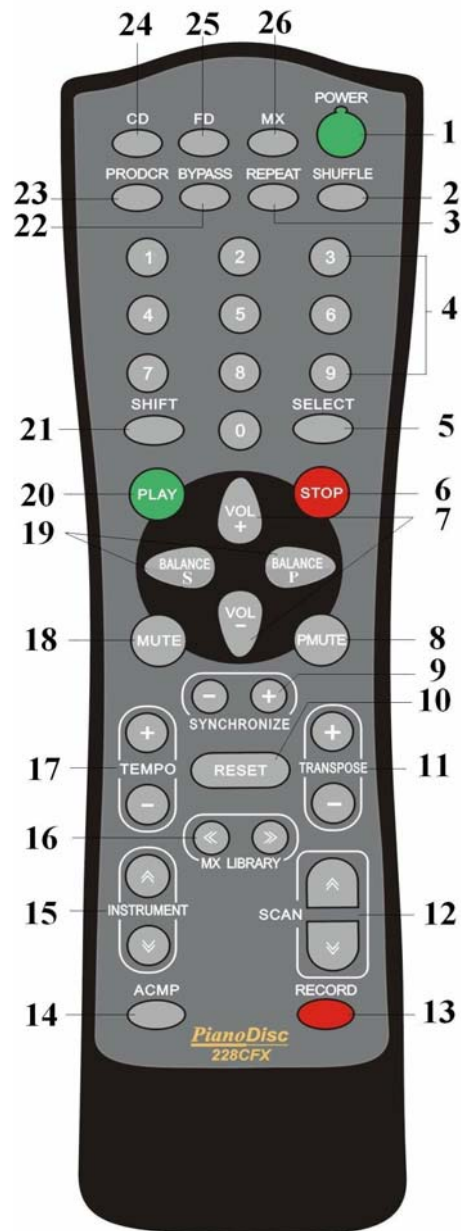

4. **REPEAT:** Accesses various repeat features.
5. **SHUFFLE:** Plays back songs in random order. To turn the SHUFFLE mode off, simply press the button again.
6. **RESET:** The RESET button returns an individual parameter (VOLUME, BALANCE, TEMPO, SYNCHRONIZE or TRANSPOSE) to its default value. First select the function to change, then press the RESET button.
7. **VOLUME:** Increases or decreases the volume.
8. **SYNC:** Aligns the piano notes with the Symphony or CD music.
9. **ACCOMPANIMENT:** Accesses the ACCOMPANIMENT mode for use with the Symphony module or external tone generator.
10. **RECORD:** Records song data onto the diskette or into an *MX* library.
11. **MX LIBRARY:** Choose active library.
12. **STOP:** Stops playback or exits the current mode.
13. **SCAN:** Forward SCAN (>>) steps through song selections. During playback it will fast-forward if held down, and advance to the next song if pressed quickly. Reverse SCAN (<<) steps through song selections in the reverse order. If pressed quickly during playback, it will return to the beginning of the song being played.
14. **INSTRUMENT:** Choose instruments in Accompaniment mode.
15. **PLAY:** Begins playback. If playback is in progress, this button toggles the pause feature.
16. **MUTE:** Silences both the piano and Symphony output. To turn on output, simply press the button again.
17. **PIANO MUTE:** Silences output to the piano.
18. **BALANCE:** Controls the relative loudness between the piano and the accompaniment.
19. **TRANSPOSE:** Raises or lowers the pitch of the song in half-step increments, up to two full octaves (24 keys) in either direction.
20. **TEMPO:** Changes the speed of song playback.

21. **SELECT:** Used in conjunction with the numeric keypad to select numeric entries. This includes directly selecting songs or selecting sounds in Accompaniment mode.
22. **SHIFT:** Used in combination with other buttons to select various functions.
23. **NUMERIC KEYPAD:** Used to select song numbers.
24. **MX:** Press to select *MX* as the source.
25. **CD:** Press to select Compact Disk as the source.
26. **FD:** Press to select Floppy Disk as the source.

Direct Song Access

When a song title is showing on the PDS-228CFX front panel display, you may go directly to the song of your choice by pressing the number of the song and then pressing the SELECT button. For example, if you would like to listen to song number 12, press button [1], then button [2], and then press SELECT. Song number 12 will then appear on the display.

Remote Control Type

Information

The PDS-228CFX remote control is an enhanced design which includes the functionality of the previous remote controls as well as direct access to more features.

It is not necessary to use the **Remote Control Type** function unless the user has misplaced the new remote and has one for the PDS-128, or PDS-128Plus. In any case, it is best to use the remote that corresponds to your control box.

If there is a problem with your remote, make sure fresh batteries are installed. To determine your remote type, compare the remote to the picture at the beginning of this section ("Remote Control"), which is the PDS-228CFX Remote Control.

Changing Remote Type

By pressing the shift button and the power button at the same time, the remote type will toggle and the display will indicate the remote type to which you have changed. Press these two buttons together again to set the next remote type. The remote type can only be changed from diskette or *MX* mode.

Section VII

Appendices

Appendix A

Accompaniment Mode Instrument List

Listed below are all the sounds available for use in the ACCOMPANIMENT mode on the PDS-228CFX. You may select any one of these sounds to “accompany” your piano performance.

01	Acoustic Grand Piano	44	Contrabass	87	Lead 7 (fifths)
02	Bright Acoustic Piano	45	Tremolo Strings	88	Lead 8 (bass+lead)
03	Electric Grand Piano	46	Pizzicato Strings	89	Pad 1 (new age)
04	Honky-Tonk Piano	47	Orchestral Harp	90	Pad 2 (warm)
05	Electric Piano 1	48	Tympani	91	Pad 3 (polysynth)
06	Electric Piano 2	49	String Ensemble 1	92	Pad 4 (choir)
07	Harpichord	50	String Ensemble 2	93	Pad 5 (bowed)
08	Clavinet	51	Synth Strings 1	94	Pad 6 (metallic)
09	Celesta	52	Synth Strings 2	95	Pad 7 (halo)
10	Glockenspiel	53	Choir Aahs	96	Pad 8 (sweep)
11	Music Box	54	Voice Ooohs	97	FX 1 (rain)
12	Vibraphone	55	Synth Voice	98	FX 2 (soundtrack)
13	Marimba	56	Orchestra Hit	99	FX 3 (crystal)
14	Xylophone	57	Trumpet	100	FX 4 (atmosphere)
15	Tubular Bells	58	Trombone	101	FX 5 (brightness)
16	Dulcimer	59	Tuba	102	FX 6 (goblins)
17	DrawBar Organ	60	Muted Trumpet	103	FX 7 (echoes)
18	Percussive Organ	61	French Horn	104	FX 8 (sci-fi)
19	Rock Organ	62	Brass Section	105	Sitar
20	Church Organ	63	Synth Brass 1	106	Banjo
21	Reed Organ	64	Synth Brass 2	107	Shamisen
22	Accordion	65	Soprano Sax	108	Koto
23	Harmonica	66	Alto Sax	109	Kalimba
24	Tango Accordion	67	Tenor Sax	110	Bag Pipe
25	Acoustic Guitar (nylon)	68	Baritone Sax	111	Fiddle
26	Acoustic Guitar (steel)	69	Oboe	112	Shanai
27	Electric Guitar (jazz)	70	English Horn	113	Tinkle Bell
28	Electric Guitar (clean)	71	Bassoon	114	Agogo Bells
29	Electric Guitar (muted)	72	Clarinet	115	Steel Drums
30	Overdriven Guitar	73	Piccolo	116	Woodblock
31	Distortion Guitar	74	Flute	117	Taiko Drum
32	Guitar Harmonics	75	Recorder	118	Melodic Tom
33	Acoustic Bass	76	Pan Flute	119	Synth Drum
34	Electric Bass (finger)	77	Blown Bottle	120	Reverse Cymbal
35	Electric Bass (pick)	78	Shakuhachi	121	Guitar Fret Noise
36	Fretless Bass	79	Whistle	122	Breath Noise
37	Slap Bass 1	80	Ocarina	123	Seashore
38	Slap Bass 2	81	Lead 1 (square)	124	Bird Tweet
39	Synth Bass 1	82	Lead 2 (sawtooth)	125	Telephone Ring
40	Synth Bass 2	83	Lead 3 (calliope)	126	Helicopter
41	Violin	84	Lead 4 (chiff)	127	Applause
42	Viola	85	Lead 5 (charang)	128	Gunshot
43	Cello	86	Lead 6 (voice)		

Appendix B

System Exclusive Messages

When using the PDS-228CFX to record music from an external MIDI device, it is possible to include system exclusive messages in the MIDI data that will specifically address the PDS-228CFX. Two such system exclusive messages are the song-naming message and the transpose-masking message.

Song-Naming

In Disk mode only, an alternative to manually naming recorded songs is to send a system exclusive message containing the song title along with the song's MIDI data. The song title will then appear automatically when recording is stopped. The format for the song-naming system exclusive message is as follows:

F0	Start of system exclusive
00 00 2A	PianoDisc ID bytes
00	PDS-228CFX product ID byte
01	PDS-228CFX device ID byte
01	Song-naming command byte
...	20 character bytes (song title)
00	End-of-name byte
F7	End of system exclusive

The characters of the title must be converted to hexadecimal (base 16 equivalents of the decimal ASCII values) using the conversion table provided on the following page. Any unused character bytes, such as those left over when a title length is less than the maximum amount of 20 characters, should be "00". It is important that the system exclusive message remains the proper length of 29. For example, to name a song (or change its name to) "Moonlight Sonata," the following system exclusive message should be recorded at the beginning of the song:

F0	00	00	2A	00	01	01	4D
6F	6F	6E	6C	69	67	68	74
20	53	6F	6E	61	74	61	00
00	00	00	00	F7			

Note: The song title is centered automatically on the PDS-228CFX display. Do not place any “00” or “20” bytes before the song title character bytes.

	0	1	2	3	4	5	6	7	8	9	A	B	C	D	E	F
2	Blank Space	!	"	#	\$	%	&	'	()	*	+	,	-	.	/
3	0	1	2	3	4	5	6	7	8	9	:	;	<	=	>	?
4	@	A	B	C	D	E	F	G	H	I	J	K	L	M	N	O
5	P	Q	R	S	T	U	V	W	X	Y	Z	[¥]	^	_
6	'	a	b	c	d	e	f	g	h	i	j	k	l	m	n	o
7	p	q	r	s	t	u	v	w	x	y	z					

Table 1. CHARACTER CONVERSION.

To convert a character in a song title, locate the character in the table, and then read the first half of the character byte from the left column and the second half from the top row. For example, the letter “M” would be represented by the byte “4D.”

Note: This feature is not available in *MX* mode.

Transpose-Masking

The following procedure is NOT NECESSARY if you are playing PianoDisc Music Library diskettes. It may be useful if you are recording your own piano and symphony music using an external sequencer. If you use the PianoDisc system only to play PianoDisc Music Library diskettes or to record piano performances on a PianoDisc with the Record option, you may skip the “Transpose-Masking” sub-section.

The TRANSPOSE function of the PDS-228CFX is a useful function, but can cause problems with drum tracks (or any unpitched instruments, percussion, or special effects) where MIDI notes should stay constant even if the song is played in a different key. Before recording a song, decide which MIDI channels should be masked so that they will not be affected by transposition. The transpose-masking system exclusive message for the PDS-228CFX should be sent (while recording the song) in the following format:

```

F0      Start of system exclusive
00 00 2A  PianoDisc ID bytes
00      PDS-228CFX product ID byte
01      PDS-228CFX device ID byte
02      Transpose-masking command byte
...     16 character bytes
F7      End of system exclusive

```

The 16 channel bytes correspond to MIDI channels 1 through 16 (the first byte refers to MIDI channel 1, the second to channel 2, etc.) If the channel is to be masked, the byte should be "01," while unmasked channel bytes should be "00." For example, to record a song with MIDI channels 4, 10, and 11 remaining unchanged by the TRANSPOSE function, the following system exclusive message would be used:

```
F0 00 00 2A 00 01 02 00
00 00 01 00 00 00 00 00
01 01 00 00 00 00 00 F7
```

The transpose-masking map defaults to all channels—except 10—unmasked for each song if no system exclusive message is sent along with the song data. The transpose masking will affect only the song with which it is recorded. It will have no effect on any following songs.

<p>Note: Channel 10 is automatically masked for transpose since it is the standard percussion channel.</p>

Appendix C

Music Software Formats

The PDS-228CFX has the ability to play the following music libraries:

- PianoDisc®
- PianoDisc Symphony
- PianoDisc PianoCD®

- Yamaha® PianoSoft™ for the Disklavier®
- Yamaha PianoSoft Plus (for the TG100, DOM30, and XG*)
- Alfred's Educational Series (for the Disklavier®)
- Other minor software providers of Disklavier music software

It can also play Standard MIDI Files by...

- Tune 1000 Corporation
- Turbo Music
- Other GM commercial software diskette (make sure they are "Type 0")
- Standard MIDI Files you make at home or download from the Internet ("Type 0" **only**)

Standard MIDI Files

A Standard MIDI File (SMF) uses a file format which contains the necessary data to reproduce music on equipment capable of reading and processing the data. Most commercial General MIDI (GM) MIDI files are released as "Type 0" Standard MIDI Files. "Type 0" is simply a single-track file. This is the most readable and accurate way of playing back a MIDI file. The PDS-228CFX is capable of playing the piano when a piano part or patch change for an acoustic piano exists on any MIDI channel. You must have the Symphony Option or an external tone module for the PDS-228CFX to play any additional sounds which are usually included on GM SMF disks. There are "educational" GM disks available which allow PDS-228CFX users to learn to play the piano. See *Appendix D* for information on setting the left and right hand piano parts for this type of disk.

WARNING

PianoDisc has done everything possible to assure that diskettes made by other manufacturers are compatible with the PianoDisc System. However, we CANNOT GUARANTEE that software diskettes produced by other manufacturers will play back satisfactorily on the PianoDisc system. In many cases, the music on these other diskettes was not produced with the intent of being played on a reproducing piano system as sophisticated as the PianoDisc, and the results can be disappointing. Please consult your PianoDisc dealer before purchasing other manufacturer's diskettes to make sure that they are compatible.

*Because the XG format uses slightly different instrument selections than General MIDI, the PDS-228CFX will make educated instrument substitutions to obtain the most satisfactory playback of such files.

Appendix D

Using Educational Software

The PDS-228CFX offers the user the opportunity to learn how to play the piano. With such software as the Yamaha Alfred's Educational Series (for the Disklavier) or GM Educational software (like Turbo Music's "You're the Star"), you can even customize the lesson and piano playback. Make sure you read the materials carefully before you use them.

The PDS-228CFX user must understand on which "channel" the left and right hand parts are located. The music materials which come with the diskettes should have this information included. To get started, read the section which describes the type of educational software you are using.

Using Yamaha® Educational Software

(Yamaha® Alfred's or the Yamaha® "You Are the Artist" series)

To use Yamaha® educational software in **FLOPPY DISK mode**, place the Yamaha® educational diskette into the floppy drive.* Press the PRODUCER button on the remote control or front panel of the control box. This feature allows the user to toggle the left and right hand parts as desired. When "RESET" is "OFF," the PDS-228CFX will play the Yamaha® Diskette while keeping the "Left" and "Right" hand parts "ON" or "OFF" (as specified on the display) throughout disk playback. When "RESET" is "ON", the PDS-228CFX will reset the left and right parts to "ON" at the beginning of the next song. Press the button below "OK" and then "Play" to get started.

*To use Yamaha® educational software files copied into **MX**: First, go to the library where the file(s) have been saved. Then—using the [SCAN << >>] buttons—scroll through the titles to find the one you wish to use. Next, press [PRODUCER]. Finally, choose EDUC. (This instructs *MX* Mode to treat the file as an educational type.) Now, you can toggle the left and right hand parts and RESET as per the above instructions.

Using Turbo Music General MIDI SMF Disks

To use Turbo Music's "You're the Star" or other educational GM SMF disks, you will need to set the channels for the "Left" and "Right" hand parts. The documentation which comes with the educational software will tell you what the educational instrument is and what channel it is on. Only use educational songs which use the acoustic piano as the educational instrument (or "Feature Performer Part" for Turbo Music diskette). You will notice that Turbo Music uses channel 1 for the "Left" hand part and channel 4 for the "Right" hand part. The default values for the PDS-228CFX are channel 3 for the "Left" and channel 4 for the "Right". You must change the "Left" part for Turbo Music. This is explained in the "EDUCATION" sub-section (under the "Diskette Mode" section).

Once the channels are set correctly, then you can get started.

*If you are accessing educational files in **Disk Mode****: Follow the same directions given on page 69, “**Using Yamaha Educational Software.**”

If you are accessing educational files in **MX*: First, go to the library where the file has been saved. Then-using the [SCAN << >>] buttons-scroll through the titles to find the one you wish to use. Next, press [PRODUCER]. Finally, choose EDUC. (This instructs *MX* Mode to treat the file as an educational type.) Now, you can toggle the left and right hand parts and RESET as per the above instructions.

Appendix E

PianoDisc CPU Interface

The picture below is of the PianoDisc CPU Interface. This interface integrates the PianoDisc *SilentDrive* player system.

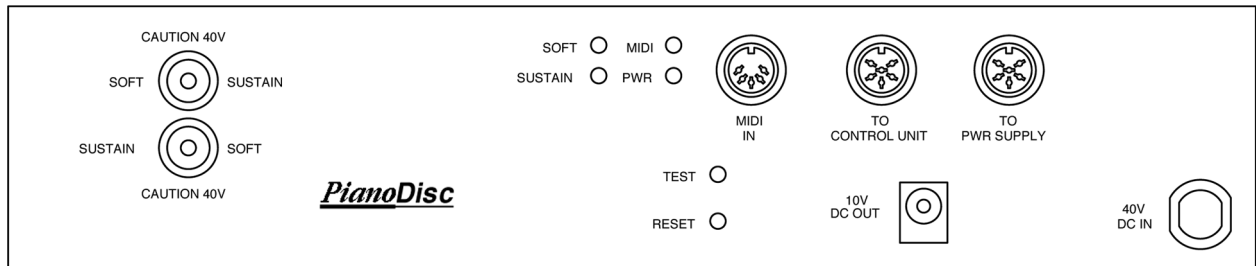

1. INDICATOR LIGHTS:

- POWER** - Indicates power is on.
- MIDI** - Flashes when MIDI data is being received.
- SOFT** - Indicates the soft pedal is on. (This feature is not available at the time of this printing.)
- SUSTAIN** - Indicates the sustain pedal is on.

2. MIDI PORTS:

- TO POWER SUPPLY** - This is a 6-pin DIN cable to be connected to the power supply only.
- TO CONTROL UNIT** - Sends and receives MIDI and CD data from the control box. This cable also supplies power to a control box.
- MIDI IN** - Receives MIDI data to be played on the piano without using the control box. *For more consistent playback, use a control box in "Passthrough" mode.*

Appendix F

Connecting a PDS-228CFX to a Stereo

Make sure all power is turned off before connecting any electrical cables.

Hooking up the PDS-228CFX to a speaker system requires two audio cables. Shielded cables are preferred and should have RCA-type connectors. RCA cables are available at most electronic stores. The PDS-228CFX rear panel includes a set of RCA stereo output jacks for use with powered speakers or a stereo amplifier system.

All sounds, which could include Symphony, Audio IN (if attached to a microphone or other audio device), and CD IN (from a CD player or other audio device), are mixed to the Audio OUT signal.

Attach Audio OUT to either powered speakers or to a stereo amplifier by connecting one RCA cable for each channel, left and right. For a stereo amplifier, connect one end of the cable to Audio OUT Left and the other end to the AUX IN Left (or other line level input). Repeat for the right channel. Once the connections have been made, select the corresponding input on the front panel of the stereo amplifier (usually Aux.). Consult your stereo's user manual for additional information. See diagram below.

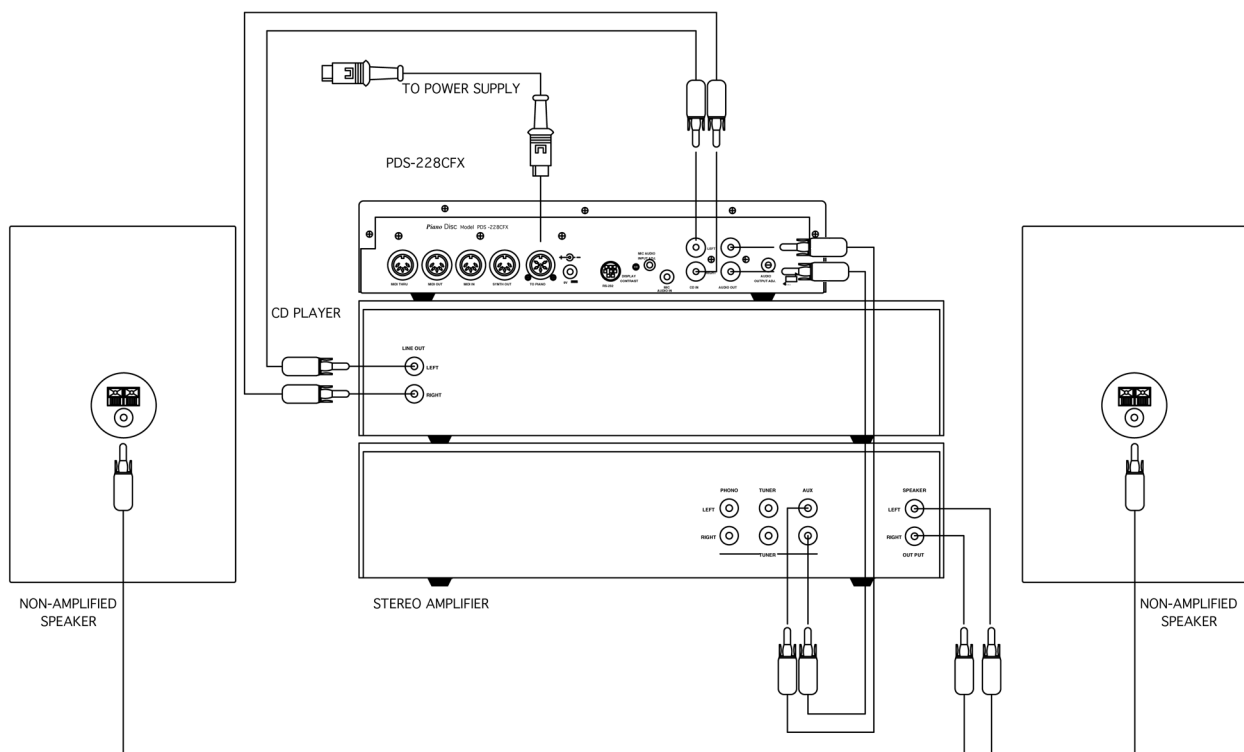

Appendix G

Connecting the PDS-228CFX to a Computer

Make sure all power is turned off before connecting any electrical cables.

To connect the PDS-228CFX to a computer, extra hardware and additional knowledge on the part of the user is required. The PDS-228CFX may be used with commercial sequencers, music software and devices which communicate through MIDI.

A sequencer can be used to edit, write, and play music on musical instruments that support MIDI—like the PDS-228CFX. Assuming that the MIDI ports have been configured properly for your computer, almost any musical piece can be patched or performed through the PDS-228CFX PASSTHROUGH mode. (Please consult your computer hardware and software user's manuals and test your MIDI setup before connecting the PDS-228CFX.) Review the PASSTHROUGH function described in this manual.

The diagram below illustrates a basic setup of the PASSTHROUGH function.

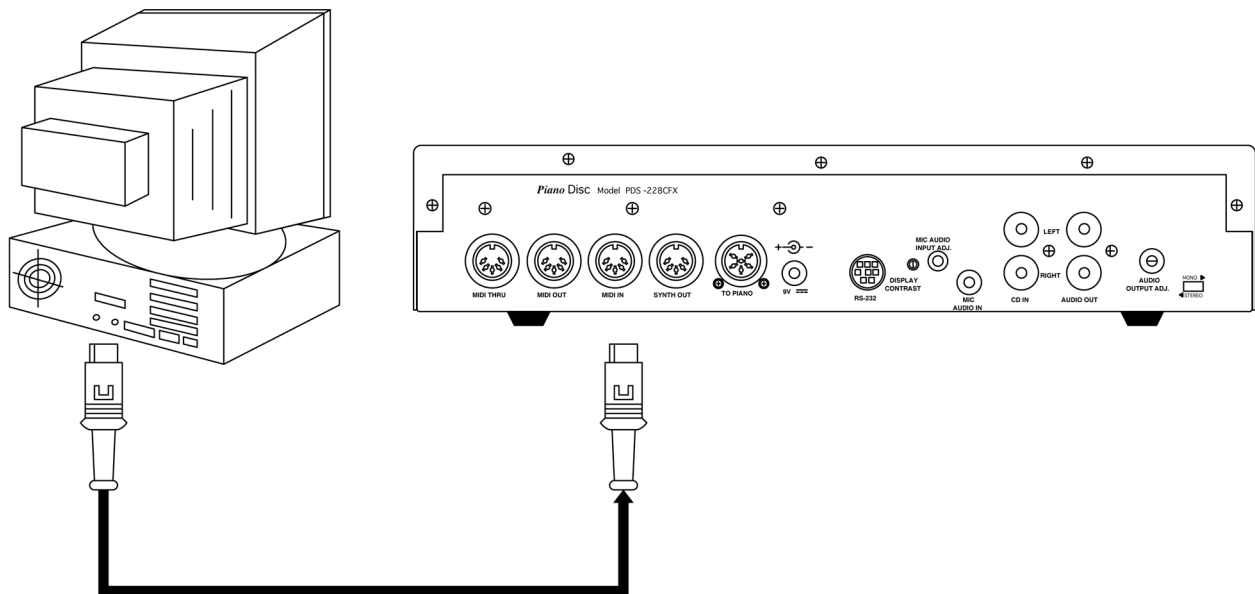

NOTE: Hardware and software required include: computer, music software, MIDI port, 5-PIN MIDI cable, and the PDS-228CFX System. Also, PianoDisc CANNOT GUARANTEE that external software and MIDI devices will be compatible with the PianoDisc system. Please consult all equipment user's manuals and your PianoDisc dealer for more information. Results may vary.

Appendix H

Software Upgrade Information

The PDS-228CFX is equipped with memory technology that allows changes in the system software to be made by inserting a software update diskette and following the update procedure. This eliminates the need for inconvenient handling of the unit to upgrade the internal programs, and assures the user of state-of-the-art performance for years to come. **For information regarding the latest in PianoDisc updates, please contact your PianoDisc dealer or visit our web site at www.pianodisc.com.**

To update the PDS-228CFX control unit:

1. Turn off the power to the PDS-228CFX by pressing the POWER button on the front panel of the PDS-228CFX.
2. Hold down the PRODUCER button while turning on the power. The display should look like this:

```
READY FOR UPDATE
Insert Program Disk
```

3. Insert the PianoDisc program diskette. The display will then show the version number of the program software on the diskette:

```
PDS / OS 4.1 14 JUL 2000
Press PLAY To Load
```

4. Press [PLAY] to load the software into the PDS-228CFX. DO NOT EJECT THE DISKETTE DURING PROGRAM LOADING. When the program has been loaded successfully, the display will read as follows:

```
PROGRAM UPDATE DONE
Please Eject Disk
```

5. Eject the program diskette. The unit will restart. The PDS-228CFX will now operate with its updated software.

Appendix I

Troubleshooting

Problem	Possible Causes	Remedies
Unit will not turn on.	Main power switch is off.	Turn on power switch under piano.
	Unit is not plugged in properly.	Check all power cord connections.
The piano does not play, even though the front display indicates playback. (Playback is indicated by the display counting real time – if the counter has stopped, playback may have PAUSED; read about PLAY/PAUSE under sub-section “PDS-228CFX Front Panel.”)	MIDI cables are not connected properly.	Make sure a cable connects TO PIANO on the control unit to CONTROL UNIT on the CPU interface.
	The MUTE function has been turned on (indicated on display).	Turn off the muting OR engage the DEFAULT settings.
	PIANO OUT has been switched off.	Make sure PIANO OUT is on. (See MIDI sub-section.)
	The piano part may be disabled.	Press default on Page 2.
Some notes do not play properly on piano.	Keys move but no sound is generated.	Piano may need to be calibrated by a PianoDisc technician.
Piano part is too loud or too soft compared to symphony background	BALANCE needs adjusting.	Adjust the BALANCE setting.

Problem	Possible Causes	Remedies
No change in loudness (symphony or piano) when VOLUME is adjusted.	The BALANCE setting is too far toward symphony (S) or piano (P).	Bring the BALANCE back toward 50%.
Song is in the wrong key or the tempo is incorrect.	TRANSCOPE or TEMPO settings have been altered.	Set TRANSCOPE to zero and TEMPO to the default value.
Not all of the songs on the disk are being played.	The songs are being played according to the diskette's producer track. (See subsection on PRODUCER.)	Press PRODUCER, and then press [CANCEL] to play the disk normally.
	SHUFFLE mode had been selected (all the songs will be played in SHUFFLE mode, but because of the random selection, some songs may not be played immediately).	Turn the SHUFFLE mode off.
Songs appear "out of order" when using [SCAN] buttons.	PRODUCER mode is active and is controlling the song order.	Turn PRODUCER Off (press the [P] button, or review the PRODUCER section of this user's guide)
The piano and symphony parts sound out of sync.	The parts need to be aligned.	Adjust SYNC until the parts line up. Generally the lower the VOLUME is set, the higher the SYNC should be set.

Appendix J

MIDI Implementation Chart

Function		Transmitted			Recognized	Remarks
		To Piano	Synth Out	MIDI Out	MIDI In	
Basic Channels	Default	1	2-16 ¹	1-16	1-16	
Mode	Default	3	3	1 ²	1 ³	
	Messages	X	X	X	X	
Note Number	True Voice	21-108 21-108	0-127	0-127	0-127	
Velocity	Note On	O, V = 0-127	O, V = 0-127	O, V = 0-127	O, V = 0-127	
	Note Off	X, V = 64	X, V = 64	X, V = 64	X	
Aftertouch	Keys	X	X	X	X	
	Channel	X	O	O	O	
Pitch Bend		X	O	O	O	
Control Change	0-63, 65	X	O	O	O	Misc. Ctrls.
	64, 66, 67	O	O	O	O	Pedals
	68-127	X	O	O	O	Misc. Ctrls.
Program Change		X	O, 0-127	O, 0-127	O, 0-127	
System Exclusive		O	O	O	O	
System Common	Song Pos.	X	X	X	X	
	Song Sel.	X	X	X	X	
	Tune Req.	X	X	X	X	
System Real Time	Clock	X	X	X	X	
	Commands	X	X	X	X	
Aux Messages	Local On/Off	X	X	X	X	
	All Notes Off	O	O	O	O	
	Active Sense	X	X	X	X	
	Sys. Reset	X	X	X	X	
Notes:	¹ Synth Out is capable of transmitting on channel 1 when in Accompaniment or Passthrough Modes, or while playing SMF disks. ² In Redirect Mode, MIDI Out does not transmit on channels 2-16. ³ When "MIDI In from Piano", channel 1 is recognized. When in Passthrough Mode or "MIDI in from MIDI", channels 1-16 are recognized.					

Mode 1: Omni On, Poly
 Mode 3: Omni Off, Poly

Mode 2: Omni On, Mono
 Mode 4: Omni Off, Mono

O: Yes
 X: No

Appendix K

MX Song List (Alphabetical within Library)

Song Title	Category	Song #
<u>Classical</u>		
Adagio (Sonata K 576)54
Aeolian Harp Etude47
Aida Selections46
Alegretto (Sonata K 576)18
Allelujah!10
Andante Cantabile (Sonata K 333)25
Anime (Sonatine)9
Arabesque In Etude Form55
Arabesque No. 124
Arabesque Op. 1831
Ballade In F Minor61
Butterfly Etude43
Clair De Lune1
Concerto In A Minor Mvmt 127
Concerto In A Minor Mvmts 2 & 328
Cujus Animam44
Dance Of The Polovetsian Maidens33
Danse Des Elfes38
Danse Macabre14
Etude Op. 10, No. 326
Etude Op. 104, No. 156
Excerpts From Rigoletto35
Fur Elise15
Gavotte Op. 2 No. 248
Gigue (French Suite)52
Habanera4
Hungarian Rhapsody No. 1253
Hut Of The Baba-Yaga, Great Gate Of Kiev21
Islamey60
Jesu, Joy Of Man's Desiring16
La Chasse (Grand Etudes)37
Loure (French Suite)12
Minute Waltz6
Modere (Sonatine)7
Moonlight Sonata5

Movement De Minuet (Sonatine)8
New World 2nd Mvmt.11
Nocturne In F Sharp Major39
Nocturne Op. 6236
Op. 32 No. 1057
Pastoral Variations34
Peter And The Wolf2
Pierrot49
Prelude And Fugue In G Minor63
Reflets Dans L'Eau40
Ritual Fire Dance58
Romance Sans Paroles32
Scherzo Op. 16 No. 241
Sevillanas (Suite Espagnole)23
Sonata In C Major, K50122
Sonata K33245
Sonata K48842
Souvenir De Porto Rico19
Spinning Song3
Staccato Caprice29
To Spring59
Troika62
Trois Ecossaises20
Un Sospiro17
Valse A La Maniere De Borodin13
Valse In C Sharp Minor30
Waltz Op. 64 No. 250
Waltz Op. 64 No. 351

Jazz

All The Things You Are10
As Time Goes By22
C Jam Blues9
Darn That Dream15
Do Nothing Till You Hear From Me13
Emily4
How Deep Is The Ocean17
In My Highest Place26
It Don't Mean A Thing20
Lady Is A Tramp18
Makin' Whoopee25
Misty6
More Than You Know8
My Blue Heaven24

My Funny Valentine	.14
Night In Tunisia	.11
On Green Dolphin Street	.1
Pensativa	.12
Pick Yourself Up	.3
Prelude To A Kiss	.19
Pretty Women	.2
Return Of The Red Baron	.7
Sheik Of Araby	.28
Star Eyes	.27
Stonewall Blues	.5
Stormy Weather	.23
Threnody	.21
Younger Than Springtime	.16

Musicals

A Wonderful Guy	.8
All I Ask Of You	.15
At The End Of The Day	.6
Can't Help Lovin' Dat Man	.14
Climb Every Mountain	.18
Do You Hear The People Sing	.17
Edelweiss	.5
I Feel Pretty	.10
If Ever I Would Leave You	.9
If I Were A Rich Man	.2
I'm Gonna Wash That Man Right Outta My Hair	.12
I've Grown Accustomed To Her Face	.11
Ol' Man River	.3
Overture (Showboat)	.1
Summertime	.7
Sunrise, Sunset	.13
Tomorrow	.4
Try To Remember	.16

Popular

Aja	.29
Baby Grand	.20
Back In The High Life	.7
Back In The USSR	.18
Blackbird	.24
California Dreamin'	.8
Classical Gas	.23

Come Sail Away	16
Daniel	2
Day After Day	25
Don't It Make My Brown Eyes Blue	33
Dust In The Wind	13
Fire And Rain	5
Georgie Girl	14
Good Vibrations	34
Greensleeves	35
I Heard It Through The Grapevine	10
Isn't She Lovely	1
Jamaica Farewell	38
Layla	9
Loves Me Like A Rock	31
Maybe I'm Amazed	11
Moondance	3
New York State Of Mind	36
Nights In White Satin	27
Roundabout	6
Scarborough Fair	32
Slow Hand	22
So Bad	30
Songbird	12
Sweet Love	26
The Rose	19
The Way It Is	21
Tuscany	17
Vincent	15
When I'm 64	28
While My Guitar Gently Weeps	37
You've Got To Hide Your Love Away	4

Sacred

A Mighty Fortress Is Our God	14
Abide With Me	18
All Creatures Of Our God And King	34
Amazing Grace	10
And Can It Be	37
Blessed Assurance	27
Brethren We Have Met To Worship	3
Come Thou Fount Of Every Blessing	35
God Be With You Till We Meet Again	39
Guide Me, O Thou Great Jehovah	6
He Hideth My Soul	12

He Leadeth Me	.11
Hiding In Thee	.9
I Am His And He Is Mine	.25
I Need Thee Ever Hour	.31
I Will Sing Of My Redeemer	.30
If Thou But Suffer God To Guide Thee	.17
Immortal, Invisible God Only Wise	.26
In The Garden	.7
It Is Well With My Soul	.5
Jesus I Am Resting, Resting	.23
Jesus The Very Thought Of Thee	.36
Leaning On The Everlasting Arms	.13
Nothing But The Blood Of Jesus	.33
O Could I Speak The Matchless Worth	.2
O Love That Will Not Let Me Go	.38
O Sacred Head Now Wounded	.15
Our God Our Help In Ages Past	.28
Praise My Soul The King Of Glory	.22
Rock Of Ages	.4
Soon We'll Be Done With The Troubles Of The World	.19
Sweet Hour Of Prayer	.24
The Church's One Foundation	.29
There Is A Balm In Gilead	.1
There Is A Wideness In God's Mercy	.32
There's A Song In The Air	.20
This Is My Father's World	.21
To God Be The Glory	.40
Were You There	.8
When Morning Gilds The Skies	.16

Country

A Long And Lasting Love	.15
Always On My Mind	.3
Blue Eyes Cryin' In The Rain	.18
Chattanooga Choo Choo	.25
Don't It Make My Brown Eyes Blue	.5
Faded Love	.9
Friends And Lovers	.7
God Bless The USA	.16
Grandpa Tell Me About The Good Old Days	.10
Green, Green Grass Of Home	.6
Help Me Make It Through The Night	.14
I Believe In Music	.19
I Can't Stop Loving You	.23

Last Date	.1
Love Me Tender	.13
Mountain Music	.4
New Fool At An Old Game	.11
Put Your Hand In The Hand	.12
Root Beer Rag	.21
She Keeps The Home Fires Burning	.25
Southern Nights	.8
Stand By Your Man	.24
The Homecoming	.20
The Most Beautiful Girl In The World	.2
We've Got Tonight	.22
Your Cheatin' Heart	.17

Vintage

3 O'Clock In The Morning	.61
After The Gold Rush	.11
Anything Can Happen	.41
As Time Goes By	.34
Begin The Beguine	.40
Berceuse	.30
Bess, You Is My Woman Now	.43
Beyond The Blue Horizon	.15
Black Orpheus	.59
Blue Monday	.32
Blue Velvet	.36
Body And Soul	.17
Bumble Boogie	.9
Cheek To Cheek	.58
Close To You	.12
Cottage For Sale	.37
Did You Ever See A Dream Walking?	.46
Edelweiss	.47
Embraceable You	.2
Fire And Rain	.8
Fly Me To The Moon	.26
Full Moon And Empty Arms	.4
Go Away From My Window	.20
Here I'll Stay	.49
I Didn't Know About You	.16
I Get A Kick Out Of You	.42
I Got Rhythm	.3
I've Got You Under My Skin	.57
Idilio	.50

It Ain't Necessarily So	.19
It's De-Lovely	.14
Japanese Sandman	.33
Jilted	.45
Just Like A Gypsy	.29
Love Is A Many-Splendored Thing	.25
Love, Here Is My Heart	.6
Lullaby	.10
Lush Life	.52
Meadow Serenade	.7
Moon River	.5
Nice Work If You Can Get It	.28
Over The Rainbow	.31
Picnic	.60
Prelude I	.53
Prelude II	.54
Prelude III	.55
Rains Of April	.22
Red Roses For A Blue Lady	.24
Say It Isn't So	.13
Skylark	.48
Sleepless Night	.35
Someone To Watch Over Me	.18
Summertime	.27
Teddy Bears' Picnic	.44
This Could Be The Start Of Something Big	.1
This Masquerade	.38
Till We Meet Again	.56
Unchained Melody	.51
Unforgettable	.39
What A Difference A Day Makes	.21
When I Fall In Love	.62
Yoo Hoo	.23

Ragtime

Ain't Misbehavin'	.6
Ain't She Sweet	.3
Alabama Dream	.66
Beat Me, Daddy (Eight To The Bar)	.29
Ben Hur Chariot Race	.56
Black Beauty	.23
Blue Turning Gray Over You	.59
Blues In The Night	.12
Cascades	.67

Charleston	16
Cow Cow Boogie	8
Cuban Love Song	39
Death Ray Boogie	65
Deep Elm Blues	60
Dude	32
Easy Winners	35
Ecuadorian Memories	10
Elephant	21
Entertainer	31
Entry Of The Gladiators	13
Glow Worm	44
Great Scott Rag	25
Haitian Blues	51
Hello Love	26
Honeysuckle Rose	57
Honky Tonk Train Blues	7
Hot Chocolate Rag	42
How Long Blues	64
I Ain't Got Nobody	53
If I Could Be With You One Hour Tonight	24
I'm Crazy 'Bout My Baby	11
Ja-Da	18
Jailhouse Blues	34
Judy	9
Kansas City	55
Kitten On The Keys	28
Lazy River	40
Let Me Call You Sweetheart	5
Lonesome Mama Blues	54
Love Is Just Around The Corner	45
Maple Leaf Rag	1
Mr. Jelly Lord	46
Muscle Shoals Blues	48
Neapolitan Nights Waltz	2
Oh Lady, Be Good	14
Pacific Coast Blues	61
Papa Better Watch Yo' Step	63
Pennies From Heaven	38
PianoDisc Boogie	52
Pinetop's Boogie	33
Railroad Blues	58
Rialto Ripples	15
Rollin' The Boogie	70
Rosetta	69
Rubies And Pearls	68

Scott Joplin's New Rag	.49
Something Doing	.4
Spanish Venus	.36
St. Louis Blues	.37
Stars And Stripes	.47
Stormy Weather	.17
Tain't Nobody's Bizness (If I Do)	.41
Take Me Out To The Ball Game	.19
Tia Juana	.27
Vicksburg Blues	.22
Washington Post March	.20
Weeping Willow	.50
What'd I Say	.2
When I Take My Sugar To Tea	.30
Working Man Blues	.43

Theme

A Spoonful Of Sugar	.9
America	.41
An Affair To Remember	.32
Anchors Aweigh	.12
Auld Lang Syne	.15
Bare Necessities	.36
Beer Barrel Polka	.16
Brahms' Lullaby	.22
Chim Chim Cher-ee	.11
Danny Boy	.29
Gentle Rain	.23
God Bless America	.30
Godfather Theme	.37
Happy Birthday	.8
Happy Trails	.43
Havah Nagilah	.4
Hi-Lilli Hi-Lo	.18
I Found Love	.40
I'm Looking Over A Four Leaf Clover	.17
Inolvidable	.27
Invitation	.25
Laura	.28
Let's Go Fly A Kite	.26
Love Story	.1
Marine's Hymn	.20
Mendelssohn Wedding March	.2
Mickey Mouse March	.34

My Dad Can't Be Crazy...Can He?	14
My Wild Irish Rose9
Once Upon A Time5
Pink Panther35
Right From The Heart10
Sabor A Mi31
Sin Ti13
So This Is Love6
Someday My Prince Will Come33
Spellbound42
Stella By Starlight38
Too-Ra-Loo-Ra-Loo-Ral3
Under The Sea21
We're In The Money7
When You Wish Upon A Star39
Whiskey In The Jar24

Christmas

A Cradle For A Lamb2
Angels We Have Heard On High37
Ave Maria12
Away In A Manger17
Bells Of Joy5
Carol Of The Bells11
Charlie Brown Christmas24
Christmas Eve Fantasy15
Christmas Meditation20
Coventry Carol7
Deck The Halls26
Fairest Lord Jesus36
For Unto Us A Child Is Born22
Frosty The Snowman19
Gesu Bambino38
Go Tell It On The Mountain10
God Rest You Merry, Gentlemen31
Good King Wenceslas25
Hard Candy Christmas18
Hark The Herald Angels Sing1
Have Yourself A Merry Little Christmas44
I Wonder As I Wander4
It Came Upon A Midnight Clear39
It's Beginning To Look A Lot Like Christmas35
Jesu, Joy Of Man's Desiring9
Jingle Bells32

Joy To The World41
Lo, How A Rose E'er Blooming30
Masters In This Hall27
O Come All Ye Faithful16
O Come, O Come Emmanuel40
O Holy Night34
Rudolph The Red-Nosed Reindeer29
Silent Night14
Silver And Gold33
Silver Bells2
Still, Still, Still8
The Christmas Song (Chestnuts Roasting On An Open Fire)13
The First Noel43
We Three Kings Of Orient Are21
What Child Is This?28
While Shepherds Watched Their Flocks By Night23
White Christmas3
Winter Holiday6

APPENDIX L

Specifications for PDS-228CFX Units

Product Description: Electronic control unit for player piano system.

Model: PDS-228CFX

Power Requirements: 9V DC @2.5A

Weight: 4.60 lbs. (2.09Kg)

Dimensions: W: 10.760 in. (27.3cm) X H: 2.165 in. (5.5 cm) X D: 8.645 in. (21.9 cm)

Audio Specifications:

Minimum R. Ch.Data input level for 'Audio In':	100 mV RMS
Sensitivity for 'Mic In.':	5mV RMS
Input Impedance for 'Mic In.' port:	22K ohm
Input Impedance for 'Audio In.' ports:	22K ohm
Output Impedance for 'Audio Out' ports:	100 ohm
Max. output signal level at 'Audio Out' ports:	7.0 V RMS @ RL=1K ohm
Output Frequency Response:	20Hz-20Khz (+/-0.5dB SPL 80Hz-20Khz)
Maximum continuous output Power (Headset):	150mW/ Channel into 32 ohms
Peak Dynamic Out put Power (Headset):	250mW/ Channel into 32 ohms
Signal to Noise Ratio (S+N) /N:	>45dB
THD @ 100mW output /Ch.:	<0.5%

CD INPUT

WARNING: PianoDisc cannot guarantee proper operation with all commercially available external CD players. When choosing an external CD player, avoid units with automatic effects processing. In order for piano data to be properly processed, the audio signal must be clean, unmodified, and must conform to the audio specifications listed above.

APPENDIX M

Quiet Time/Silent Function

This addendum is for the PDS-228 player system equipped with a quiet time mute rail.

The purpose of the mute rail is to keep the hammers from touching the strings but yet maintain the touch of the piano. At the same time, the sensor strip under the keys sends information to the control box sound card then to the headphones or speakers. The purpose of the mute rail is to silence the piano for private listening.

NOTE: The piano must be equipped with the record option and a sound card in the control box.

How to use the Quiet Time/Silent function:

- A. Muting the piano
 1. Locate the Quiet Time lever under the keybed (left side).
 2. Move the lever to the right to mute the piano.

- B. Selecting the "Floppy Mode"
 1. Press the "Power" button at the far left side of the control box.
 2. Press the "C/F/X" button once.
 3. Press "FD" (floppy disk) button 1, then press "OK" button 4.

- C. Selecting a sound
 1. Press the "Mode" button once. (Button with 3 pages under the screen)
 2. Press button 2 or "KBRD" button once.
 3. Press button 3 or "ACMP" button once.
 4. Press button 3 or "YES" button once.

NOTE: Now the control box will display "Accompaniment Mode" and the sound selection on the screen.

5. For a private session, plug headphones into the left side, front port of the control box. The back port allows speakers to operate as well as the headphones.
6. Now use buttons 1 and 4 to scan through sound selections. The users guide (page 64) shows a list of sounds available on the sound card. Only one sound can be chosen at a time.
7. Use the volume buttons to control the volume.
8. To cancel the Accompaniment Mode, simply press stop twice.

INDEX

- Accompaniment Mode, 21
- Accompaniment, 20, 59
- Advancing Songs, 21
- Audio In, 6
- Audio Input Control, 6
- Audio Out Connectors, 6
- Audio Output Control, 6
- Auto, 17
- Balance, 17, 39, 40, 59
- Bass, 39, 44
- ByPass, 39, 45
- By-Pass, 58
- CD Activity Light, 3
- CD Drive, 3
- CD Eject, 3
- CD In Connectors, 6
- CD Input, 89
- CD Mode, 38
- CD, 60
- Changing Sounds, 20
- Connecting (Computer), 73
- Connecting (Stereo), 72
- Control Unit (To), 71
- Controls, 8
- Copy, 53
- CPU Interface, 71
- DC Power Connector, 5
- Decrease Volume, 3
- Default, 15, 28, 39, 44, 49
- Defeat, 39, 45
- Dimensions, 89
- Direct Song Access, 61
- Disk Drive Activity Light, 3
- Disk Drive, 3
- Disk Eject, 3
- Disk Repeat, 23, 50
- Display Contrast, 6
- DSDD, 14
- DSHD, 14
- Education, 22
- Erase, 15, 29, 53
- Exiting Accompaniment Mode, 21
- External Tone Generator, 21
- FD, 60
- Features, 8
- File, 49
- Floppy Disk Mode, 14, 15
- Format, 15, 29, 31
- Free, 15, 29, 31
- Front Panel Functions, 32
- Front Panel, 2
- Function Buttons, 2
- Global Repeat, 24, 41, 51
- I.R. Sensor, 2
- Increase Volume, 3
- Indicator Lights, 71
- Instrument List, 64
- Instrument, 59
- Keyboard, 15, 49
- LCD Display, 3
- Library, 49, 52
- Mask, 49, 54
- MIDI Implementation Chart, 77
- Midi In, 26,
- Midi Out, 26
- Midi Ports, 5, 71
- Midi Thru, 5
- Midi, 15, 49, 71
- Mode Pages, 15, 39, 49
- Mode, 2
- Mono/Stereo Selector Switch, 6
- Music Software Formats, 68
- Music Source, 11
- Mute, 39, 43, 59
- MX Library, 59
- MX Logo, 3
- MX Mode, 48
- MX Song List, 78
- MX, 60
- Name, 15, 29, 30, 49, 52
- Numeric Keypad, 60
- Passthrough, 28
- Pause, 3
- Piano Mute, 18, 39, 43, 59
- PianoDisc Floppy Disk, 14
- Play, 3, 11, 15, 49, 59
- Playback Status, 3
- Power Requirements, 89

Power Supply (To), 71
Power, 2, 58, 71
Producer, 2, 32, 55, 58
Product Description, 89
Quick Start, 10
Rear Panel, 5
Record, 2, 33, 59
Recording (External Midi Device), 33
Recording (Symphony Accompaniment), 35
Recording Procedure, 34
Redirect, 27
Remote Control Type, 61
Remote Control, 58
Remote Type (Changing), 61
Repeat, 15, 39, 49, 59
Reset, 59
RS-232 Port, 6
Scan Backward, 2
Scan Forward, 2
Scan, 59
Scope, 15, 25, 49, 50
Select, 60
Shift, 60
Shuffle, 24, 41, 51, 59
Side Panel, 7
Soft, 71
Software Upgrade, 74
Song Repeat, 23
Source, 2, 15, 28, 39, 43, 49
Specifications (Audio), 89
Specifications, 89
Split High, 19
Split Low, 19
Split, 18
Standard MIDI Files, 68
Stereo Headphones, 7
Stop, 3, 59
Sustain, 71
Symphony Logo, 4
SymphonyPro, 14
Sync, 15, 25, 39, 40, 49, 59
Synth Out, 5
System Exclusive Messages, 65
System Info, 10
Tempo, 16, 59
To Piano, 5
Transpose Masking, 66
Transpose, 16, 39, 42, 59
Treble, 39, 44
Troubleshooting, 75
Turbo Music, 69
Volume Level, 11, 59
Weight, 89
Yamaha Educational Software, 69